



INGLESE

Dizionario Visuale

Termini ricorrenti

Corso per Volontari Operativi Generici di Protezione Civile

realizzato secondo gli Standard Regionali in materia di Formazione per la Protezione Civile

D.G.R. 4036/2007 - Scuola Superiore di Protezione Civile -I.Re.F.





Sommario e Credits

❖ Perche' questo incontro:

- ❖ L'informatica e la lingua inglese fanno parte delle quotidiano nella vita e nelle emergenze. Anche non volendo spesso siamo portati al loro utilizzo

❖ In questo documento:

- ❖ Il computer e i suoi componeti
- ❖ Internet e motori di ricerca
- ❖ Posta elettronica (email)

❖ Organizzazione:

- ❖ Associazione Nazionale Carabinieri – Nucleo Volontariato e Protezione Civile – Brugherio
- ❖ Relatore: Rosario Villa – Coordinatore Gruppo Comunale Protezione Civile Lodi Nord, IT Manager in un azienda di distribuzione informatica





Natural Disasters

- ❖ Hurricanes (uragani)
- ❖ Tornadoes (tornado)
- ❖ Floods (inondazioni)
- ❖ Wildfires (fulmini)
- ❖ Earthquakes (terremoti)
- ❖ Volcanoes (vulcani)
- ❖ Tsunamis
- ❖ Epidemics (epidemie)





Human-Caused Disasters

- ❖ Transportation accidents (incidenti nei trasporti)
- ❖ Hazardous materials spills (sversamento di materiale pericoloso)
- ❖ Industrial accidents (incidenti industriali)
- ❖ Wars (guerre)
- ❖ Terrorist acts (attacchi terroristici)





Disaster Consequences

Effects on physical Health (effetti sulla salute)

- Injuries (ferite)
- Disease (malattie)
- Death (morte)





Effects on emotional well-being

Distress (angoscia)

- Fear and anxiety (paura e ansia)
- High-risk behaviors like drinking (comportamenti ad alto rischio come il bere)
- Psychological illness like depression (malattie psicologiche come la depressione)





Damage to property and services

**Damage, destruction, or service disruption
(Danneggiamento, distruzioni):**

- Homes (case)
- Schools (scuole)
- Businesses, factories, workplaces (uffici, fattorie, posti di lavoro)
- Hospitals (ospedali)
- Government offices and services (amministrazione pubblica)
- Gas stations (distributori di benzina)
- Utilities (power, water, television, telephone, Internet) – elettricità, acqua, televisione, telefoni, internet.





Effetti sulla comunità'

- Interruption of activities (interruzione delle attività')
- Closure of schools, workplaces, and government offices (chiusura di scuole, posti di lavoro, amministrazioni pubbliche)
- Unemployment (disoccupazione)
- Displacement of people whose homes are damaged (sfollati, senza casa)
- Economic losses (perdite economiche)
- Transportation (trasporti)





Frasi utili

Aiuto! **Help!**

Chiamate la Polizia **Call the Police, please.**

Poliziotto **Agent, Officer**

Fuoco! **Fire!**

Pompieri **Fireman**

Uscite (subito)! **Get out (now)!**

Fermo! **Stop!**

Scappa! **Run!**





Preposizioni

PREPOSITIONS	PREPOSIZIONI	PREPOSITIONS	PREPOSIZIONI
ON	Equivalente italiano	AT	Equivalente italiano
<p>ON</p> <p>The lesson starts on time</p> <p>We have English on Mondays</p> <p>My pen is on the table</p>	<p>IN</p> <p>La lezione inizia in orario</p> <p>Abbiamo inglese il Lunedì</p> <p>La mia penna è sul tavolo</p>	<p>AT</p> <p>We arrive at the station at 2.30</p>	<p>AL/ ALLA Arriviamo alla stazione all 2.30</p>
<p>BETWEEN</p> <p>The school is between the Post Office and the supermarket</p>	<p>FRA DUE</p> <p>La scuola è fra la posta ed il supermercato</p>	<p>NEXT TO</p> <p>The blackboard is next to the teacher's desk</p>	<p>ACCANTO</p> <p>La lavagna è vicino/accanto alla cattedra</p>





Preposizioni

<p>IN FRONT OF</p> <p>The students are sitting in front of each other</p>	<p>DI FRONTE</p> <p>Gli studenti sono seduti uno di fronte all'altro</p>	<p>OPPOSITE</p> <p>The teacher is opposite the students</p>	<p>DI FRONTE/ DI RIMPETTO</p> <p>L'insegnante è di fronte agli studenti</p>
<p>ABOVE</p> <p>The light is above the desks</p>	<p>SOPRA senza contatto</p> <p>La luce è sopra i banchi</p>	<p>OVER</p> <p>The helicopter flies over the houses</p>	<p>SOPRA</p> <p>L'elicottero vola sopra le case</p>
<p>IN</p> <p>The pens are in the pencil case</p> <p>The children are in/at school</p> <p>STATO IN LUOGO</p>	<p>DENTRO</p> <p>Le penne sono Dentro l'astuccio</p> <p>I bambini sono a scuola.</p>	<p>TO</p> <p>We go to school on foot</p> <p>The children go to School</p> <p>MOTO A LUOGO</p>	<p>VERSO</p> <p>Andiamo a scuola a piedi</p> <p>I bambini vanno a scuola</p>





What's the weather like?

It's sunny	C'è il sole	It's raining	Piove
It's a nice day	E' una bella giornata	It's a rainy day	E' una giornata Piovosa
It's cloudy	E' nuvoloso	It's foggy	E' nebbioso
It's hazy	C'è foschia	There is a fog	C'è la nebbia
It's snowing	Nevica	It's haling	Grandina
It's windy	C'è vento	There is a storm	C'è un temporale





Temperatures?

It's hot	Fa caldo
It's warm	E' tiepido
It's mild	E' mite
It's cool	E' fresco
It's cold	E'/fa freddo
It's freezing	Si gela





The weather forecast?

Sunshine	Sole, soleggiato	Cloudy at times	Nuvoloso a tratti
Rain	Pioggia	Showers at times	Piogge sparse
Snow	Neve	Sleet	Nevischio
Ice on the roads	Strade ghiacciate	Foggy	Nebbia





Keywords?

What's the weather like today?	Che tempo fa oggi?
What is the temperature like today?	Che temperatura c'è oggi?





Eating out

I WOULD LIKE....

VORREI....

COULD I HAVE.....

POTREI AVERE.....

May I have the menu please?

Potrei avere il menù per favore?

Of course sir/madam, here you are

Certo signore/signora, tenga

What would you like to start with?

Con cosa desidera cominciare?

I'd like....

Vorrei....





Making call

Greetings:
Hello/ good morning/ good afternoon

Saluti:
Ciao/buongiorno/ buon pomeriggio...

Identify yourself:
I'm Patrick /I'm Mr. Black

Identificarsi:
Sono...

Get the person you want to speak to

Farsi passare la persona desiderata:

**Can I/ May I speak
to Mr. Smith please?**

Posso/potrei parlare con..

**Could you put me through to
Mr. Black please?**

Potrebbe passarmi ...





Making call

<p>Explain the purpose of the call</p> <p>I'm calling about the tickets</p>	<p>Spiega le ragioni della chiamata</p> <p>Chiamo per i biglietti</p>
<p>Talk about the main topic:</p> <p>There is a problem with the new equipment</p>	<p>Parla dell'argomento principale :</p> <p>C'è un problema con la nuova attrezzatura</p>





Making call

<p>Discuss the matter: I believe we should...</p>	<p>Discuti il problema: Credo che dovremmo</p>
<p>Express agreement: I agree..</p> <p>Express disagreement: I'm sorry, but I don't agree</p>	<p>Esprimi la tua identità di vedute: Sono d'accordo..</p> <p>Esprimi il tuo disappunto: Mi dispiace, non sono d'accordo</p>





Making call

Signal the end of the call:

Well, we can discuss the matter further/

I'm glad we have reached an agreement

Far capire che la conversazione si chiude:

possiamo discutere ancora dell'argomento/

sono felice che abbiamo raggiunto un accordo

Goodbye

Arrivederci





Beeng polite – Can I/ May I

Can I open the window?	Posso aprire la finestra?	Of course I'd rather not	Certo Preferirei do no
May I open the door?	Potrei aprire la finestra? (più formale)	Of course I'd rather not	Certo Preferirei do no
Can we smoke?	Possiamo fumare?	I'm afraid it's not Allowed	Temo che non sia Permesso
May we smoke?	Possiamo fumare? (più formale)	Yes of course.	Certo.
Can I help you ?	Posso aiutarla?	Yes please, I'd like a T shirt for my son	Grazie vorrei una T shirt per mio figlio
Can I see your driving licence please Sir?	Posso vedere la sua patente signore?		
May I see your driving licence please Sir?	Potrei vedere la sua patente signore? (più formale)	Of course Here you are	Certo Tenga





Can you?/Could you? Seconde persone

Can you help me please?

Mi puoi/può/potete aiutare per favore?

Could you help me please?

Mi potresti/potrebbe/potreste aiutare per favore?





Terremoto

EARTHQUAKE

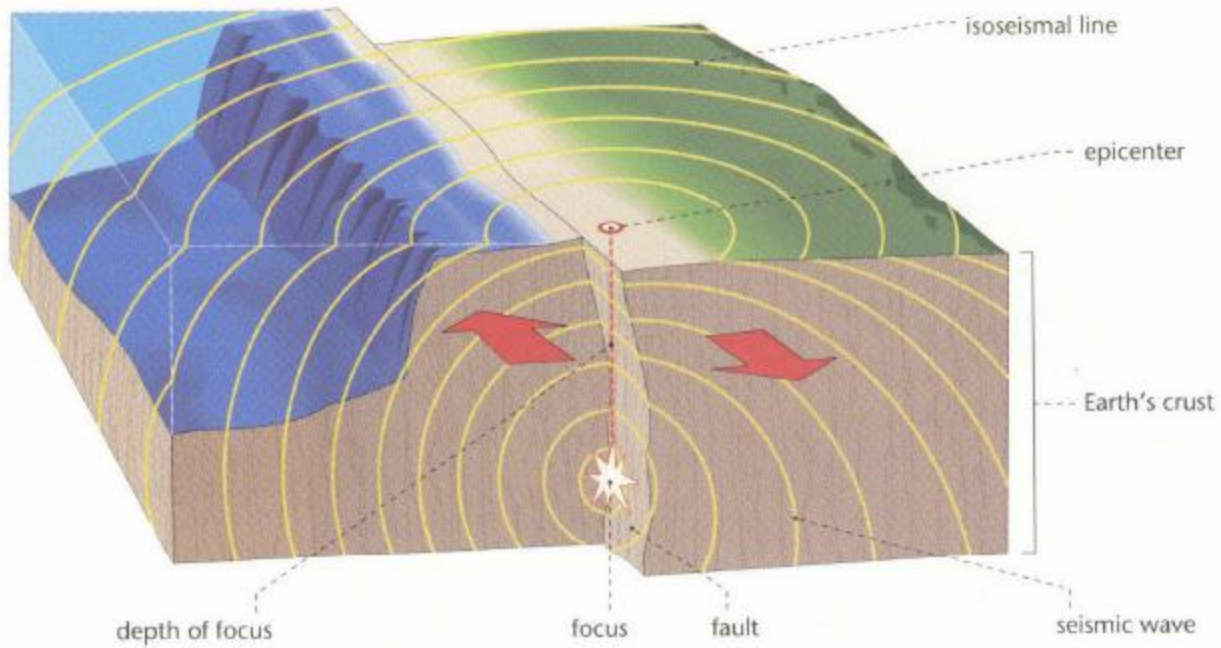



Vulcano

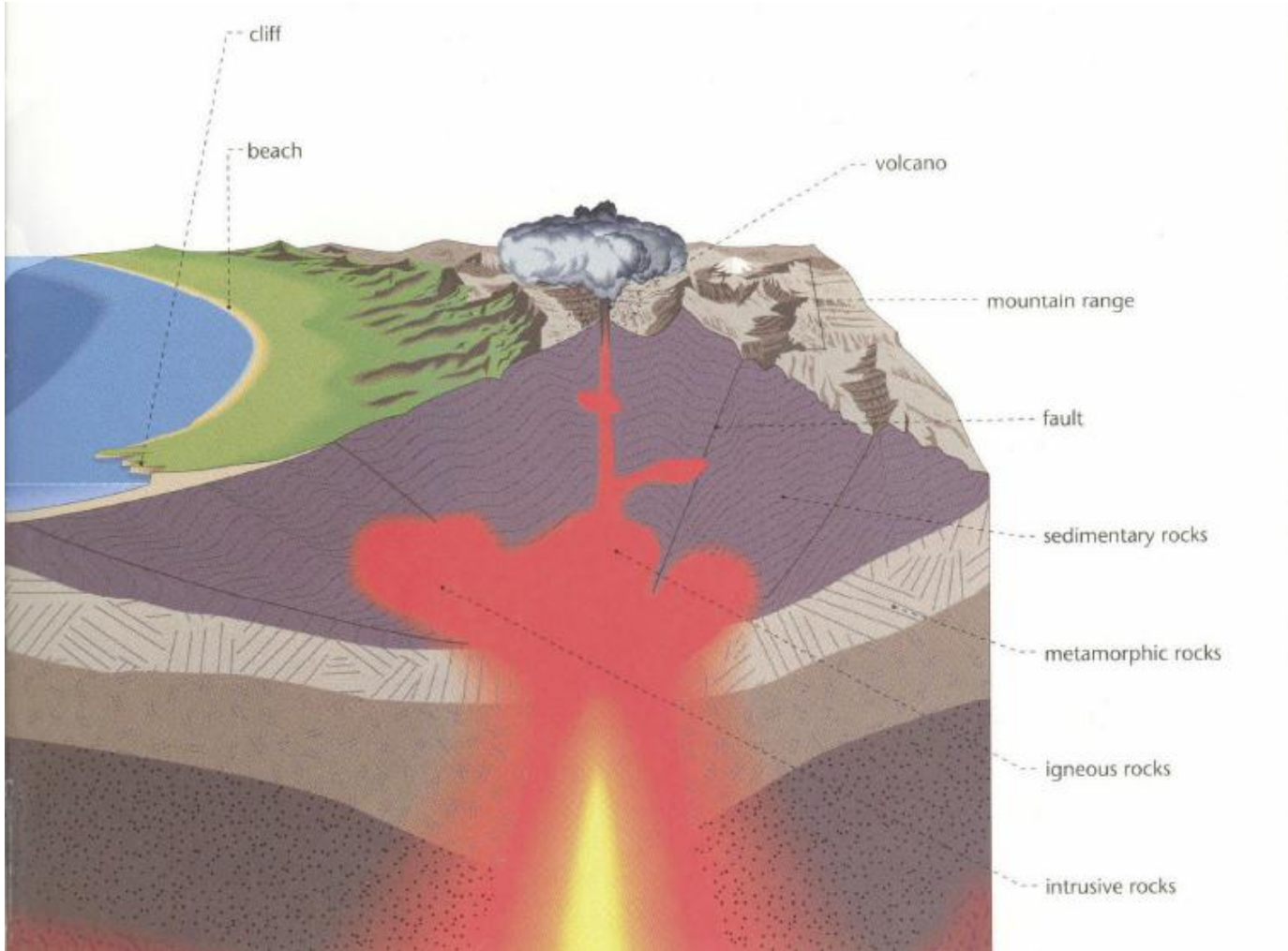



Caverna

CAVE

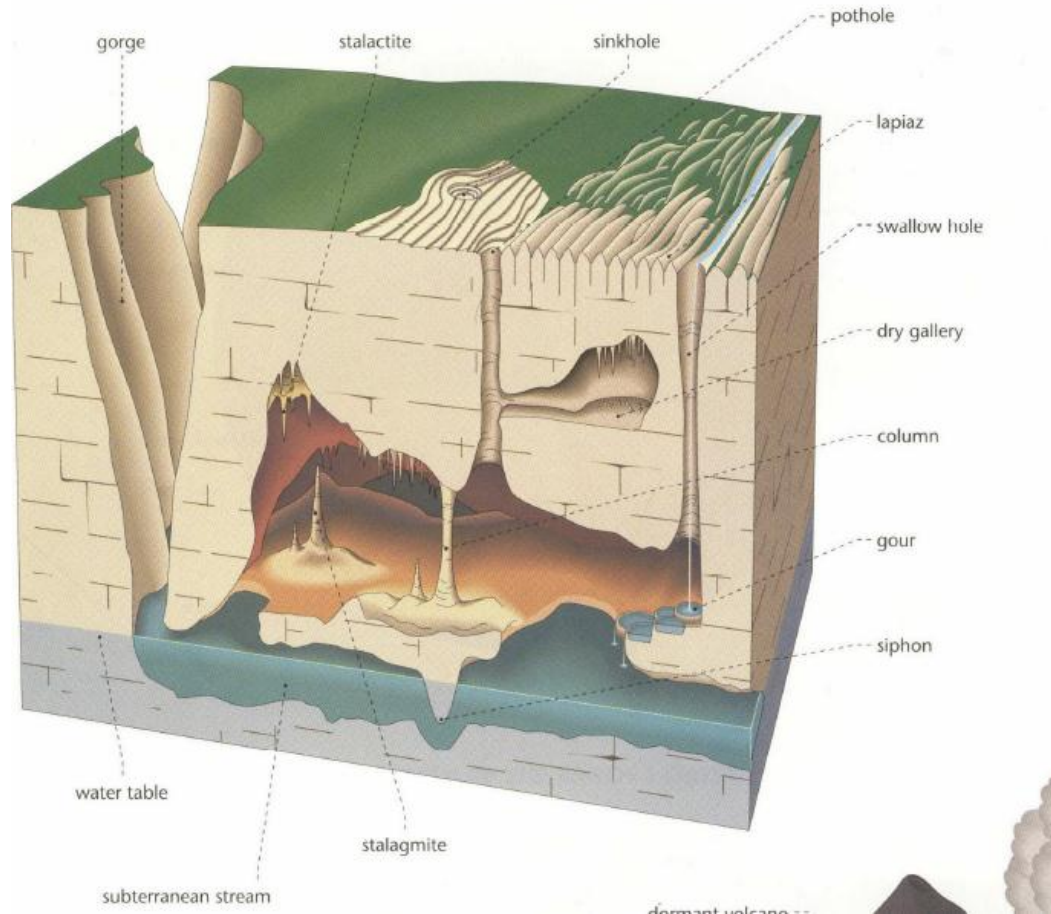



Vulcano

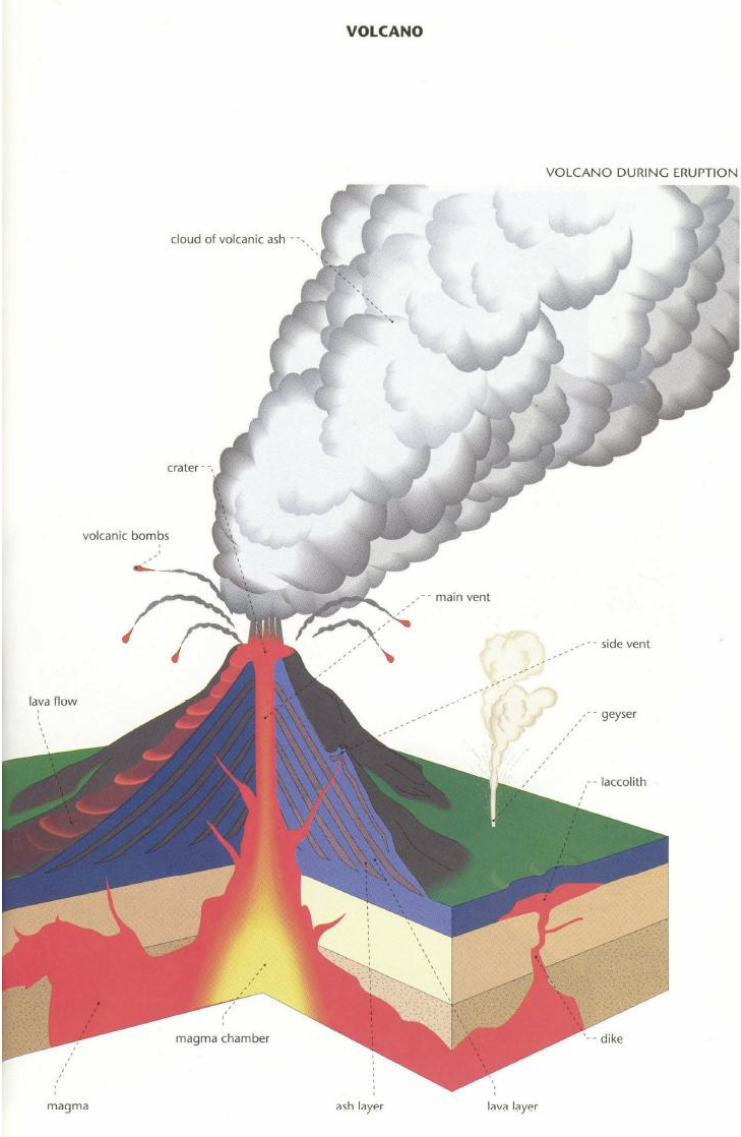



Ghiacciaio

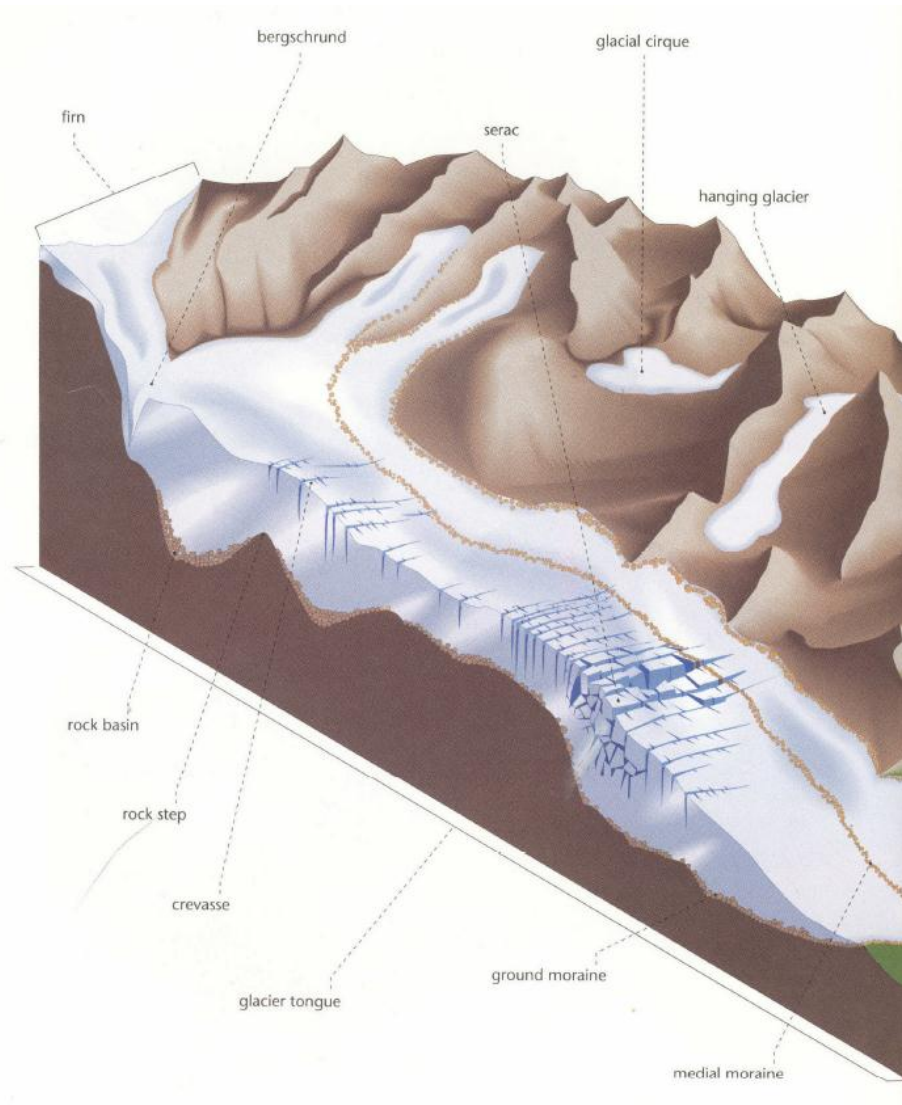



Montagna

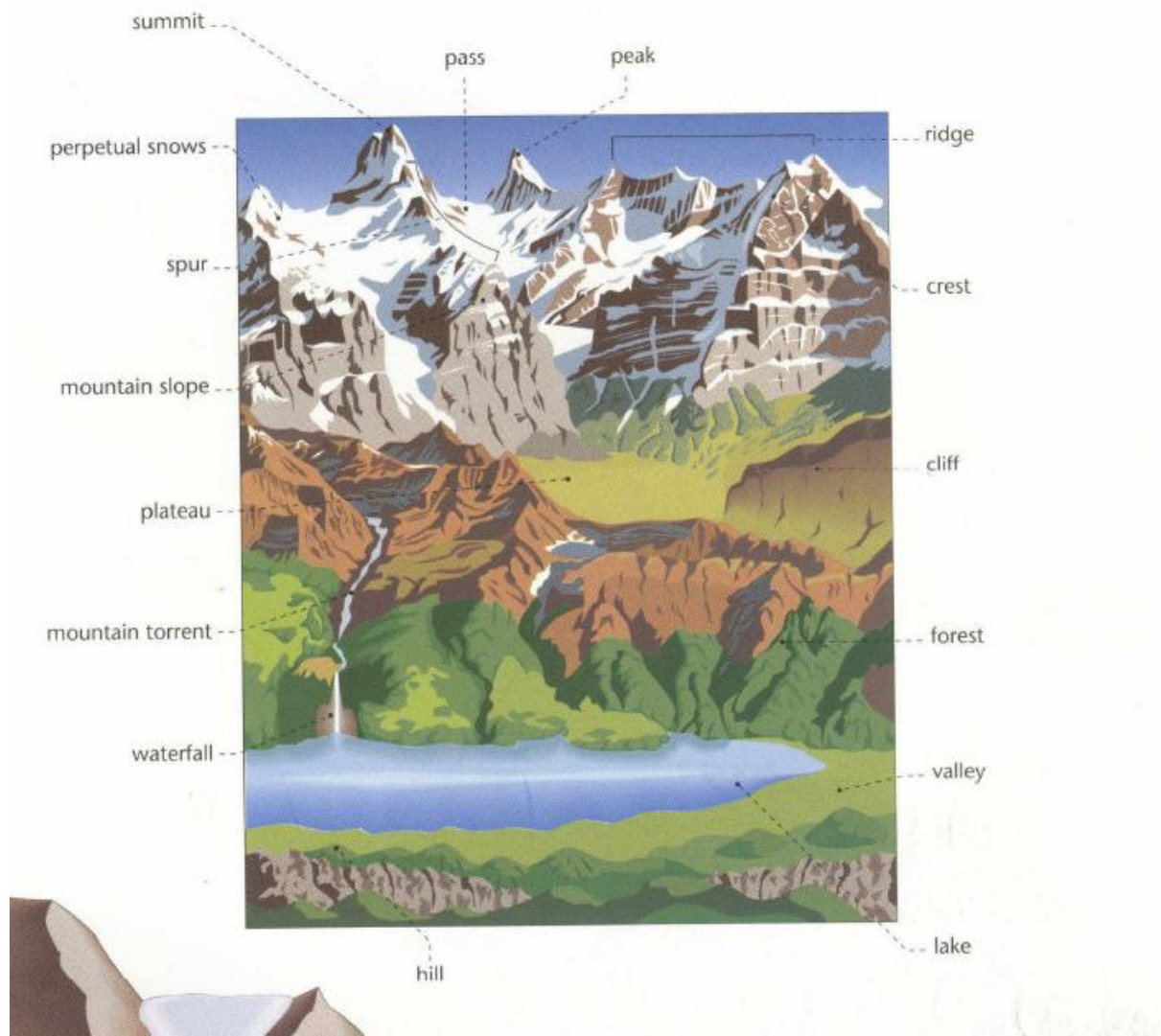



Montagna

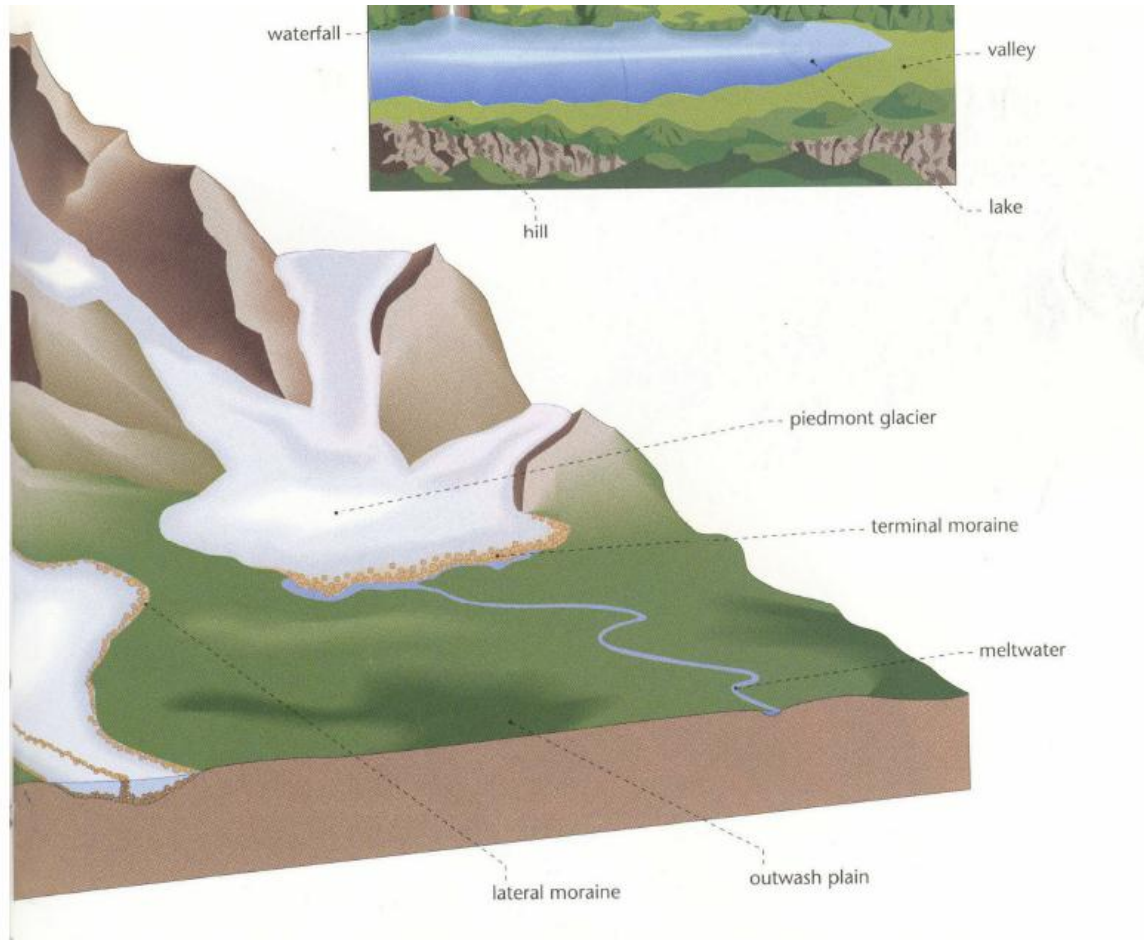



Moto ondoso

WAVE

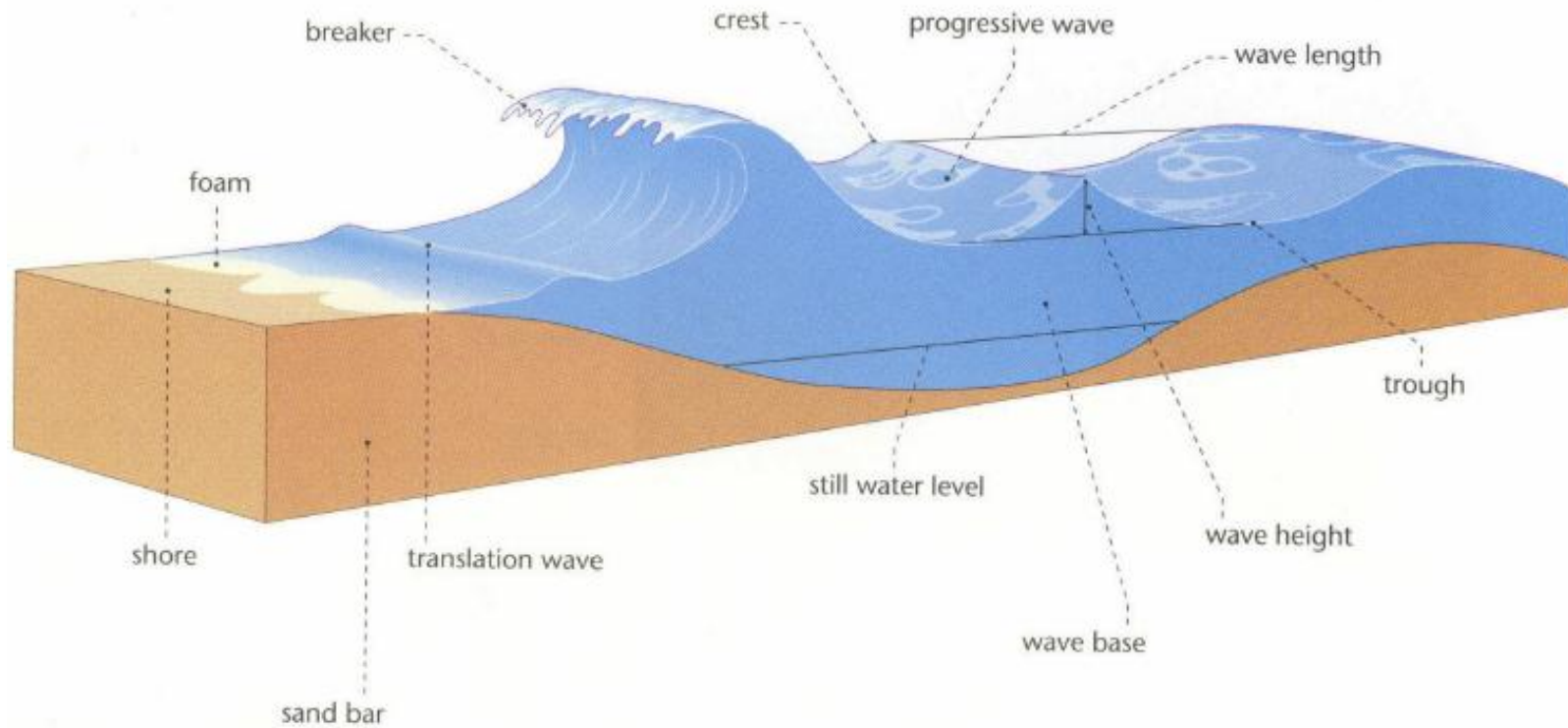



Coste

COMMON COASTAL FEATURES

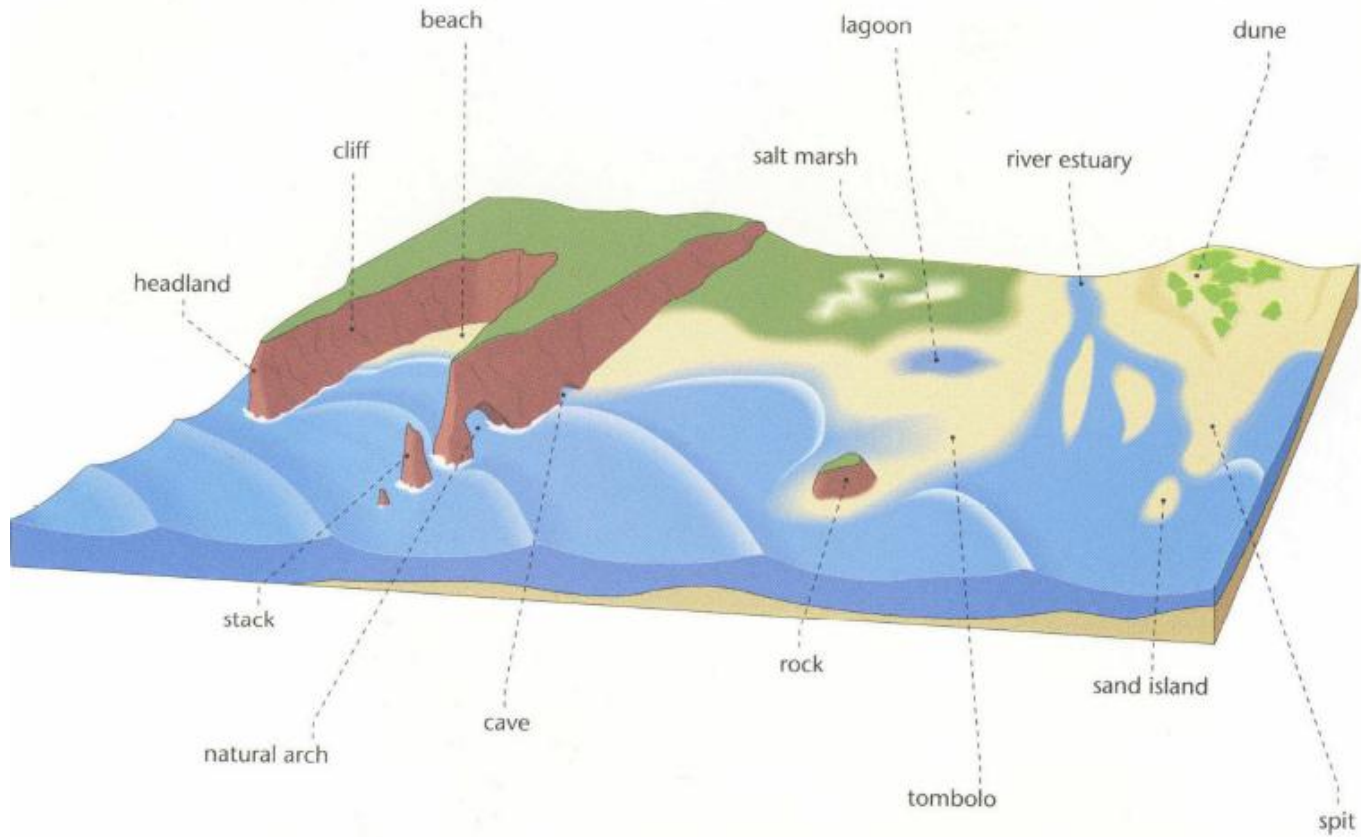



Precipitazioni

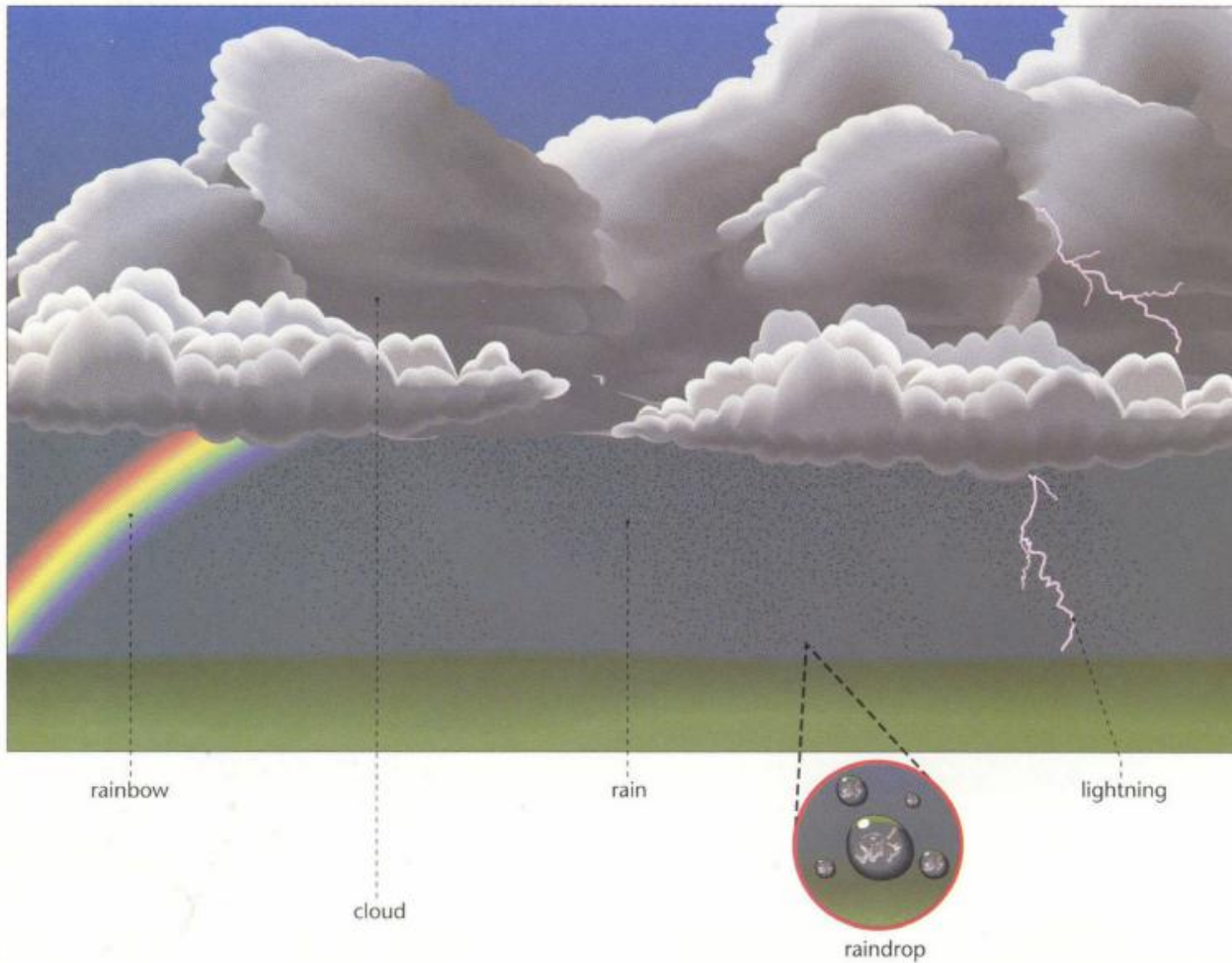



Tempo



mist



fog

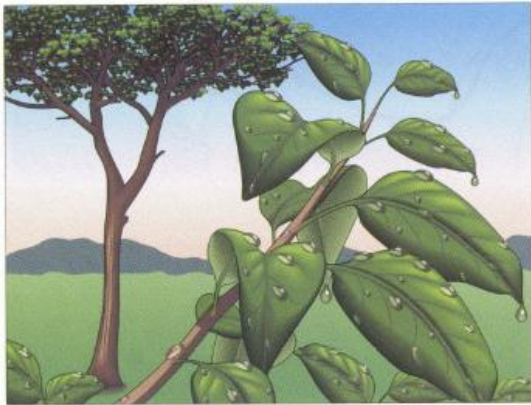

dew



frost





Meteorologia

METEOROLOGY

WEATHER MAP

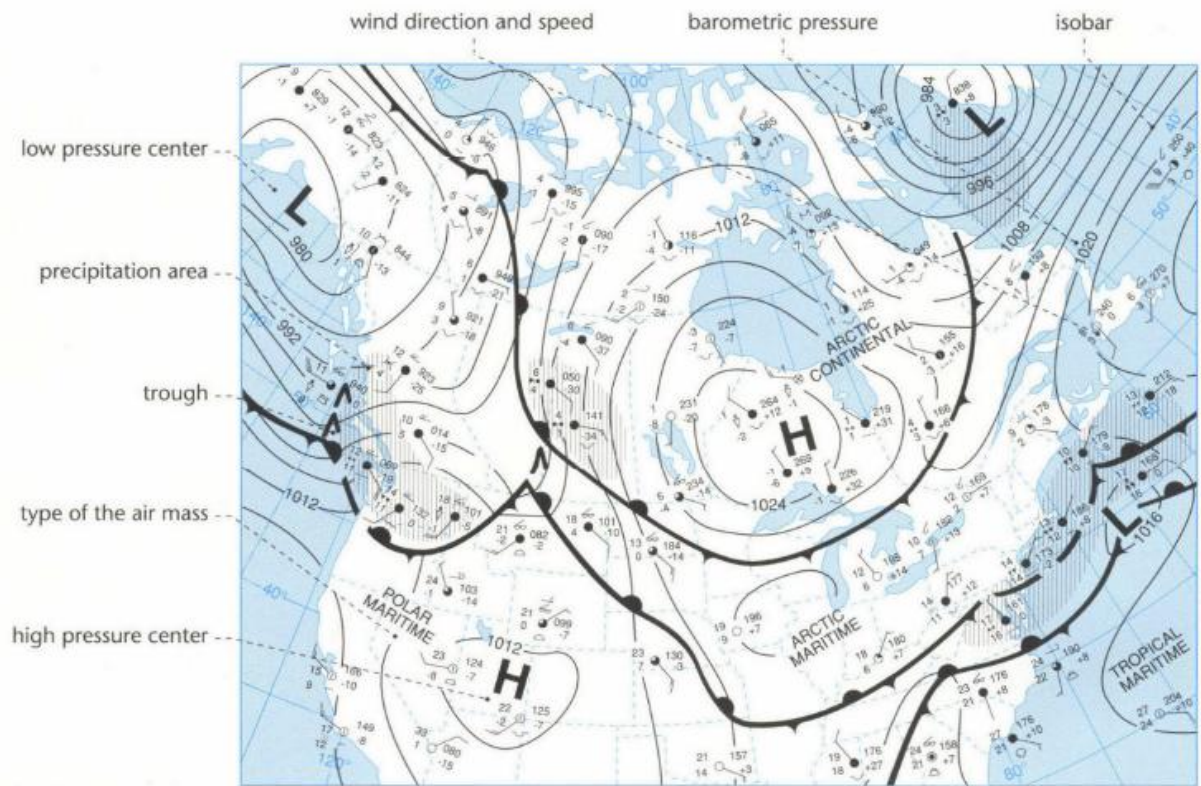



Meteorologia

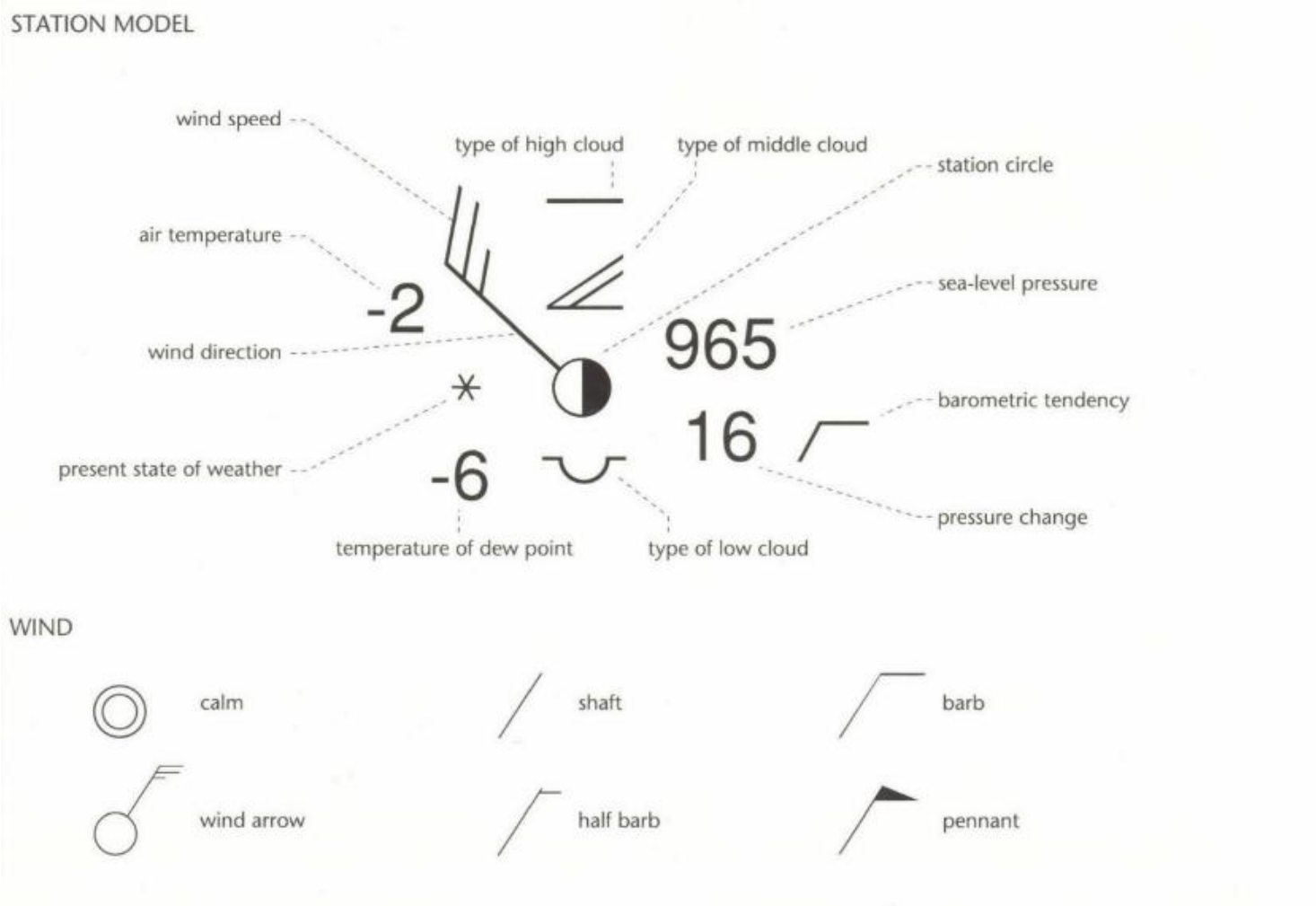



Meteorologia

INTERNATIONAL WEATHER SYMBOLS

FRONTS

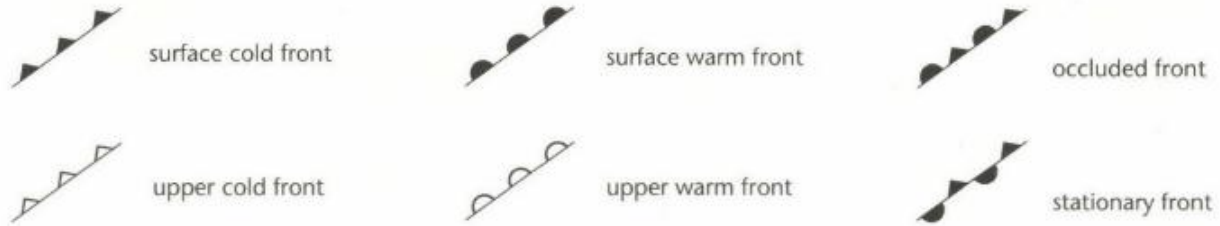

SKY COVERAGE

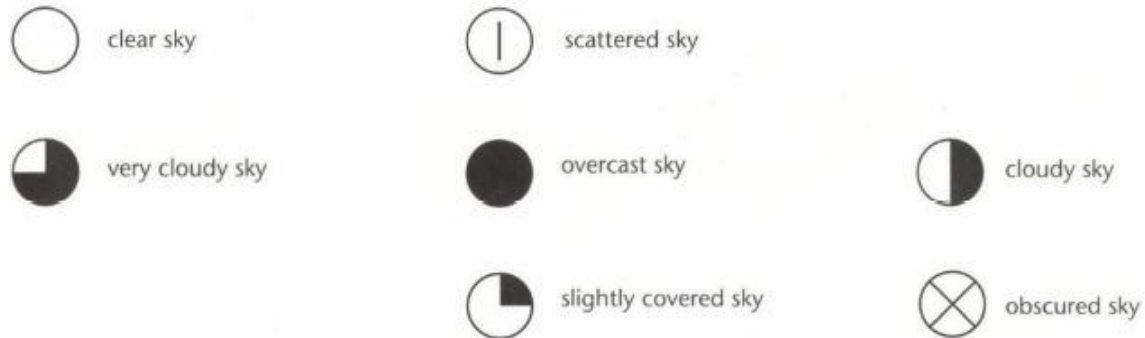



Meteorologia

PRESENT WEATHER

●	intermittent rain		snow shower		
●●	continuous rain		thunderstorm		sleet
‘	intermittent drizzle		heavy thunderstorm		hail shower
’’	continuous drizzle		sandstorm or dust storm		squall
*	intermittent snow		tropical storm		freezing rain
**	continuous snow		hurricane		smoke
	rain shower		slight drifting snow low		mist
			heavy drifting snow low		fog





Meteorologia

CLOUDS AND METEOROLOGICAL SYMBOLS





Citta'





Strade

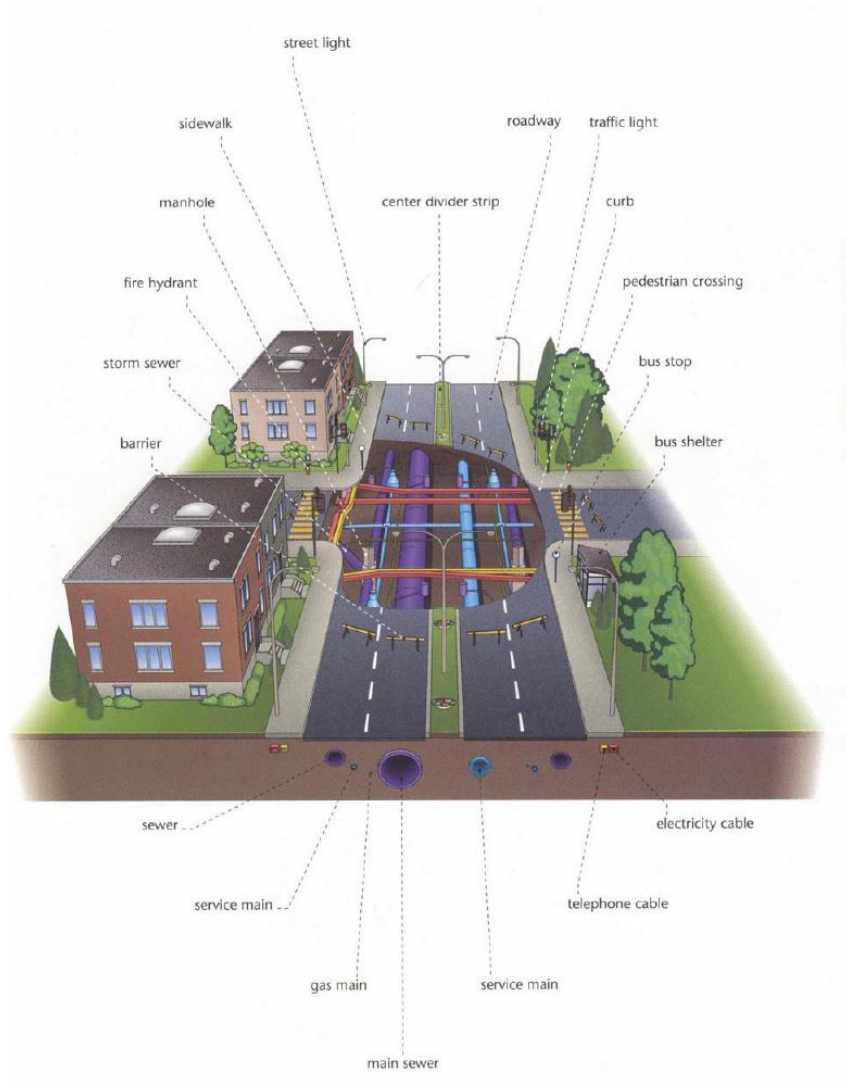



Attrezzi

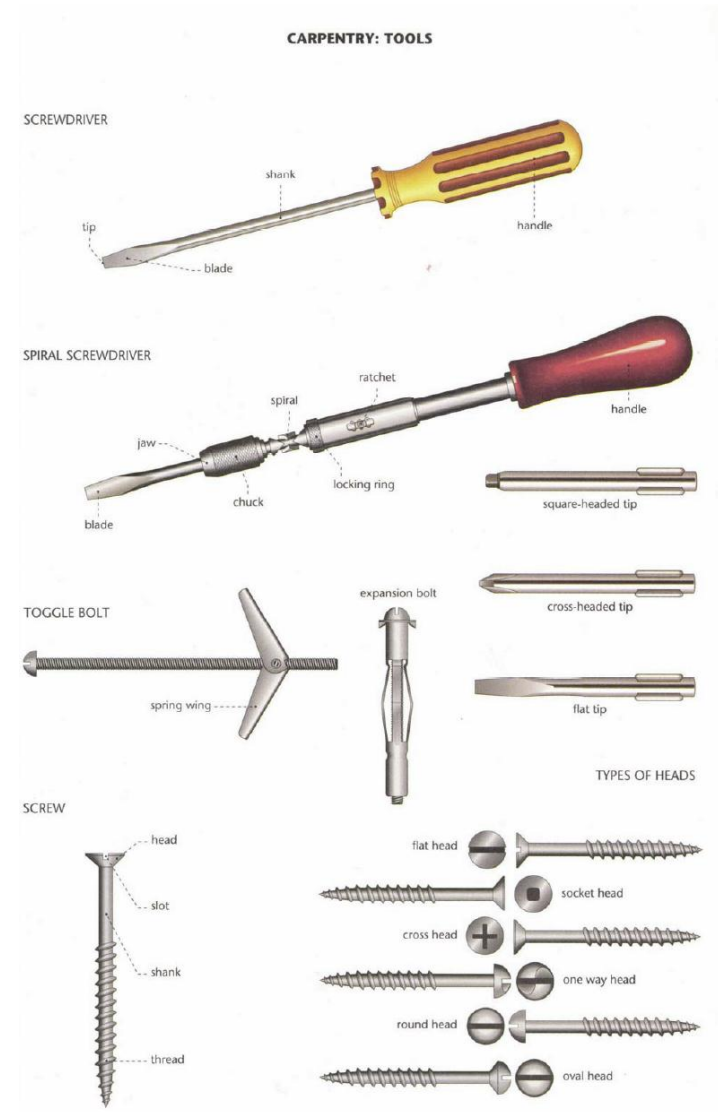



Attrezzi

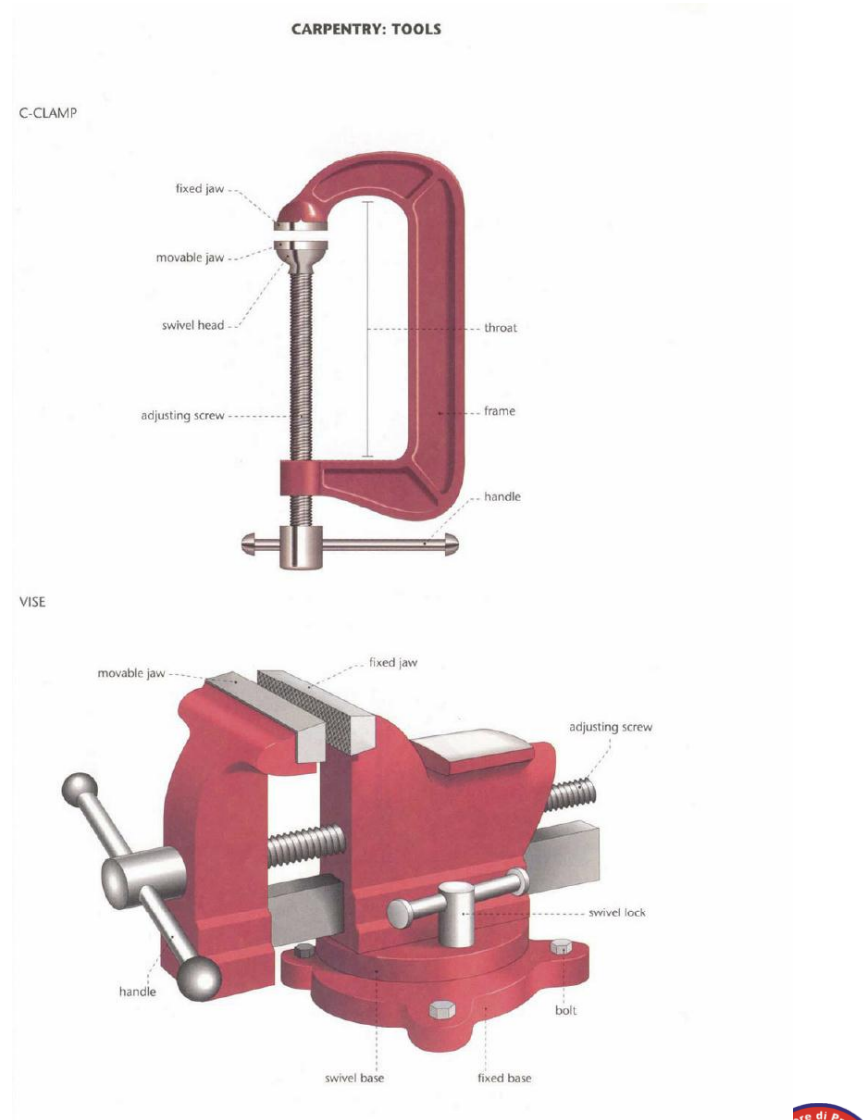
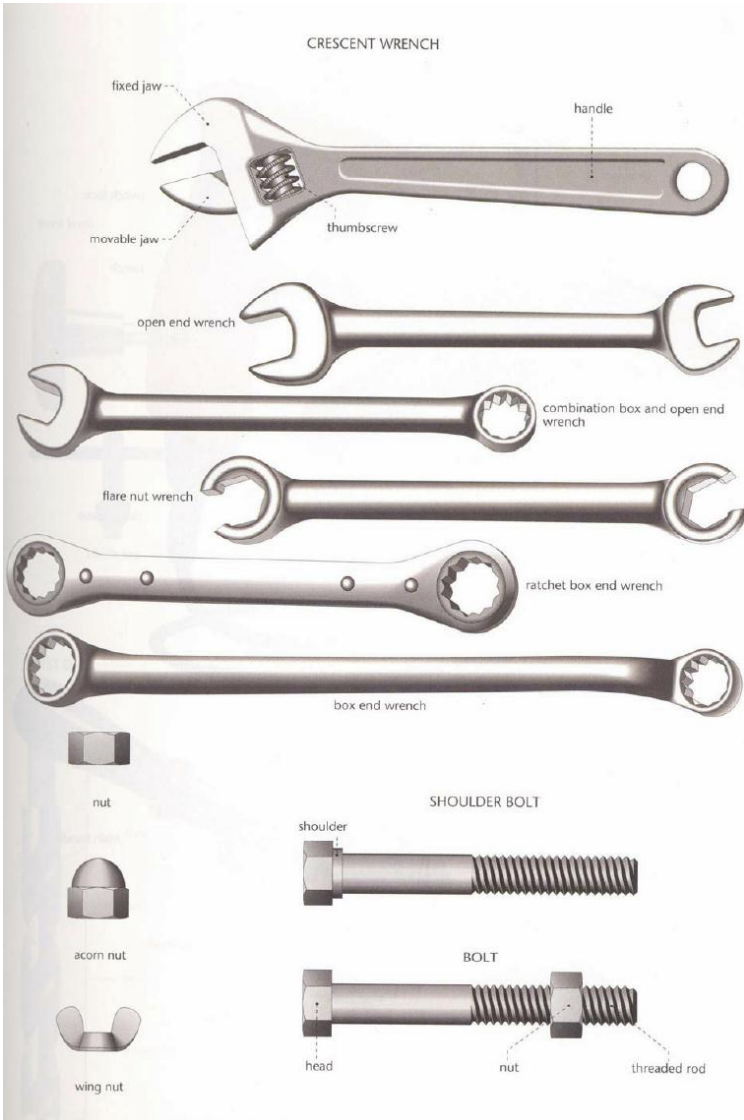



Attrezzi

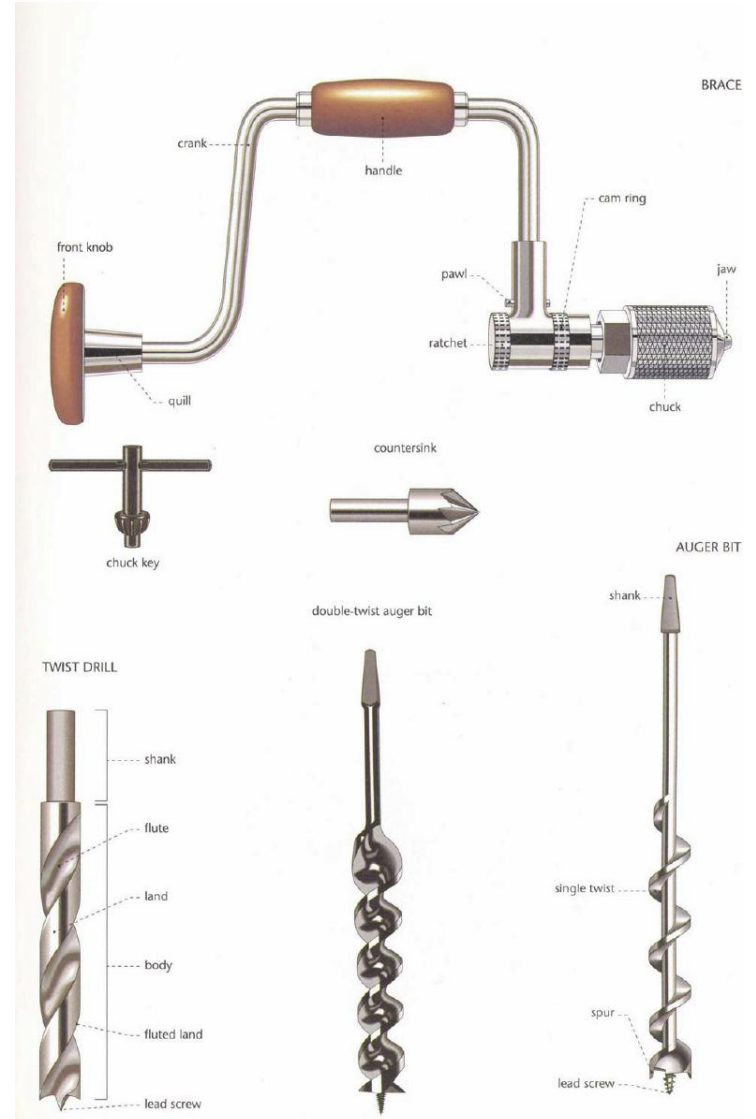
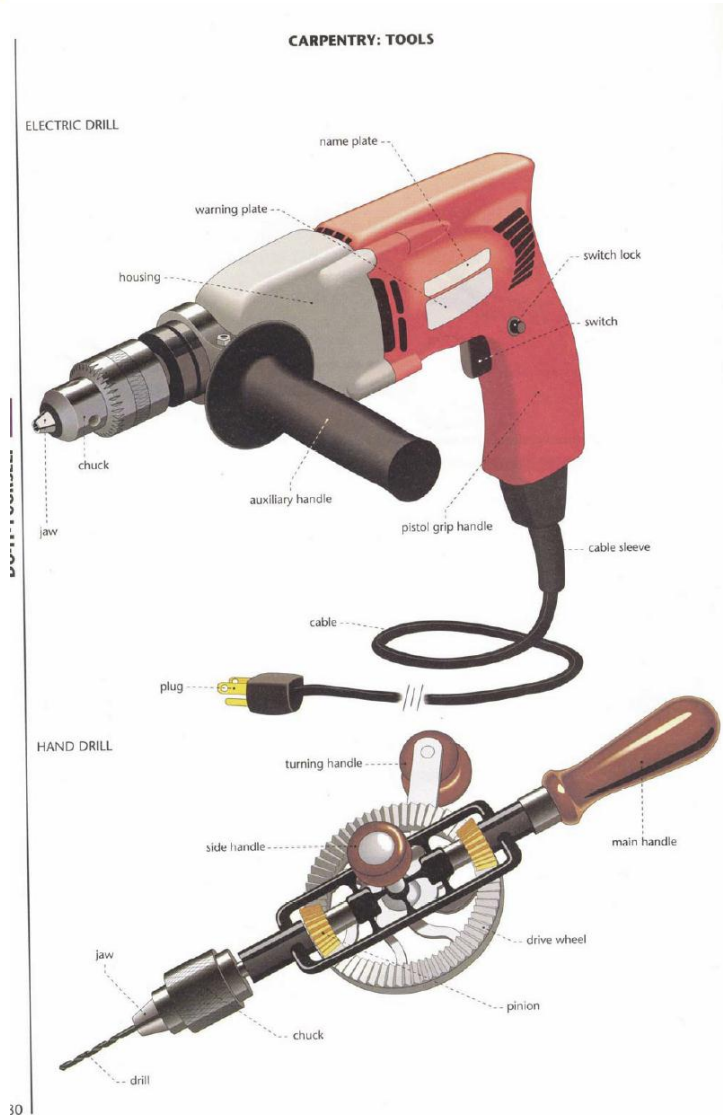



Attrezzi

CARPENTRY: TOOLS

CIRCULAR SAW BLADE

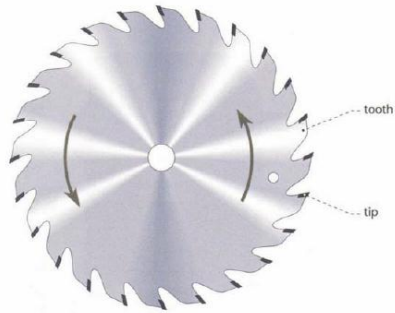

CIRCULAR SAW

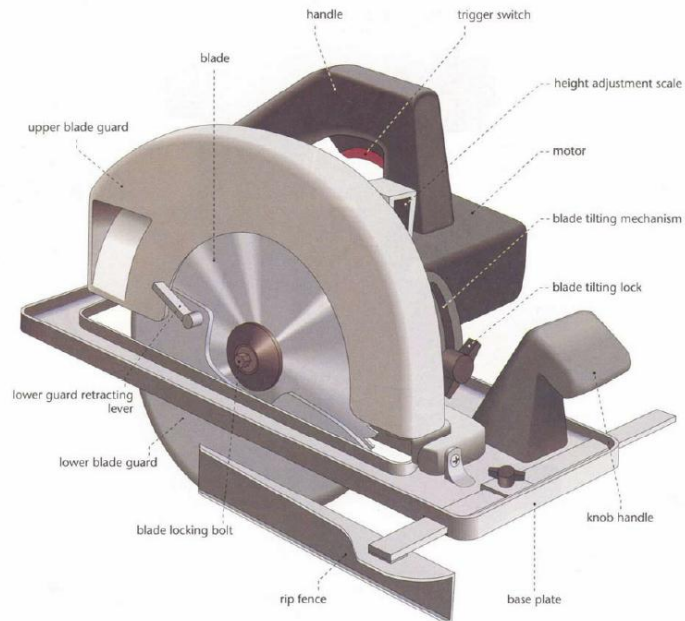

MASONRY

MASON'S TROWEL



square trowel

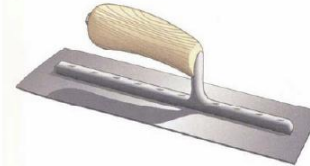

bricklayer's hammer



hawk



joint filler



spirit level



CAULKING GUN

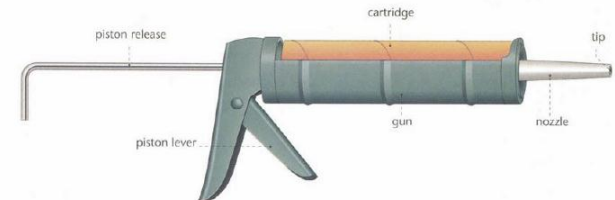

Materaiali

BUILDING MATERIALS

BASIC BUILDING MATERIALS

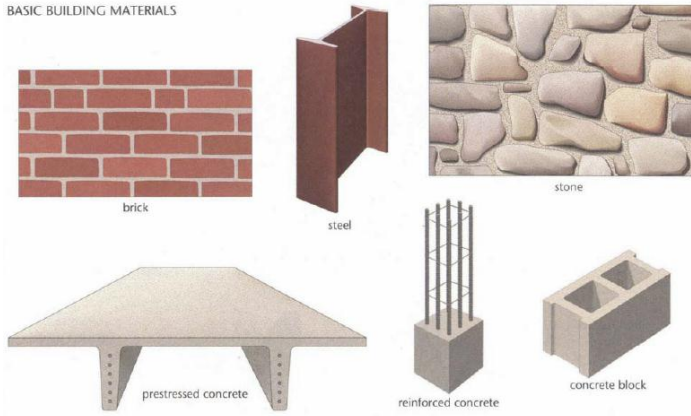

COVERING MATERIALS



BUILDING MATERIALS

WOOD

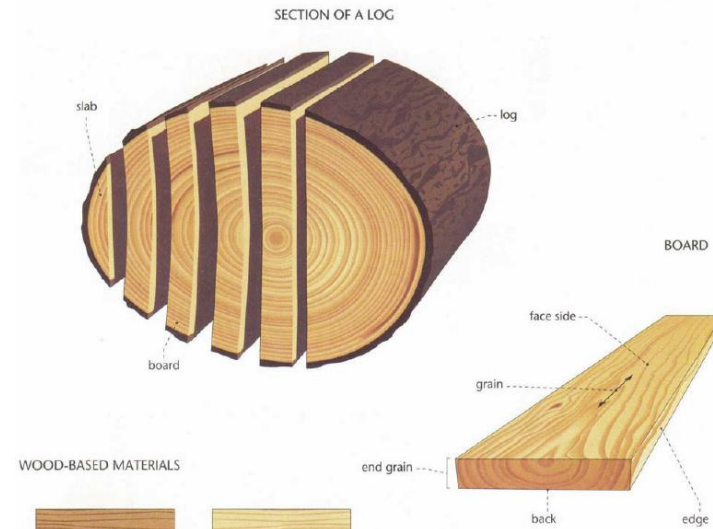

WOOD-BASED MATERIALS

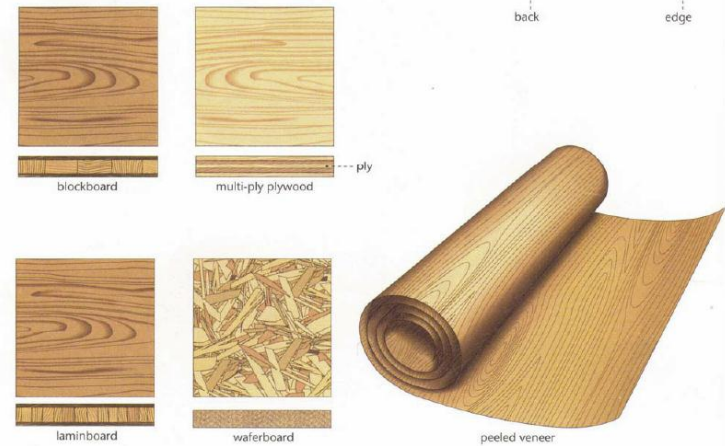



Attrezzi

PLUMBING

PLUMBING TOOLS

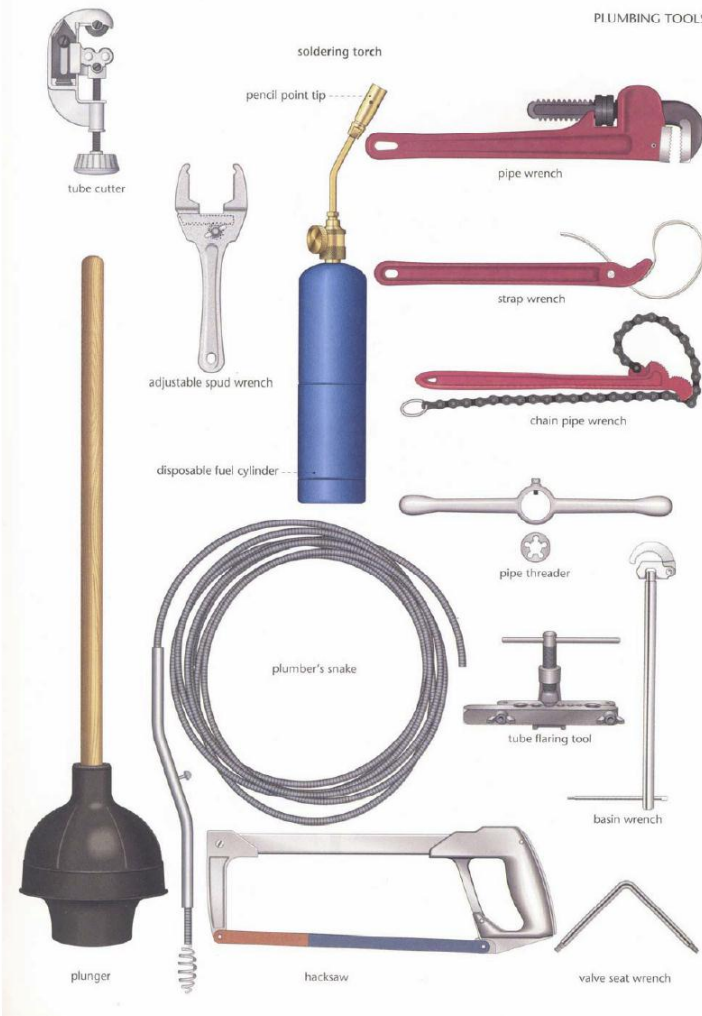

TRANSITION FITTINGS



FITTINGS





Scale

LADDERS AND STEPLADDERS





Saldatura

SOLDERING AND WELDING

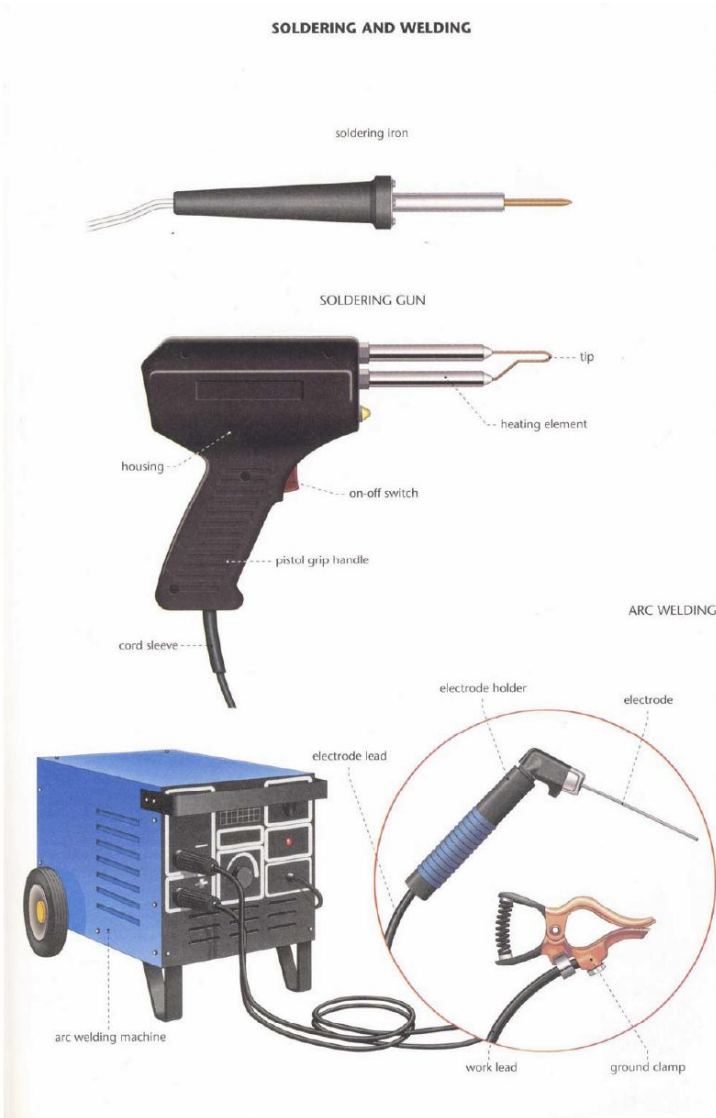

SOLDERING AND WELDING

CUTTING TORCH

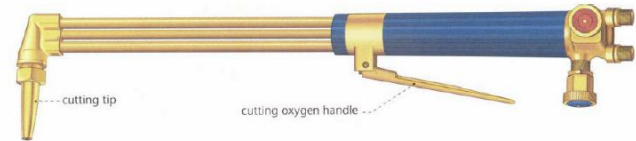

WELDING TORCH

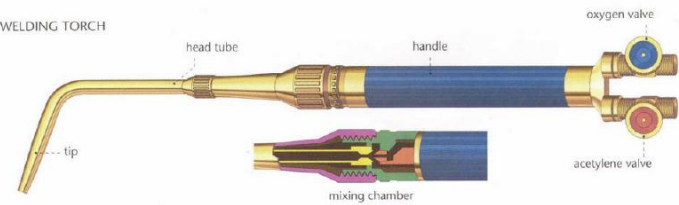

OXYACETYLENE WELDING

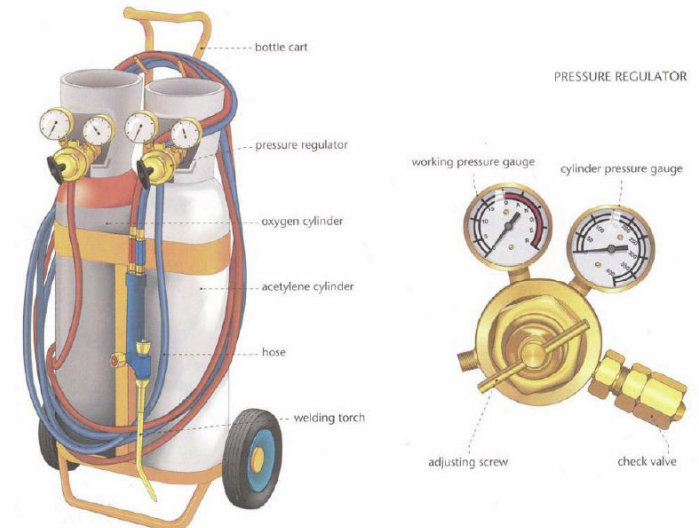



Saldatura

SOLDERING AND WELDING: PROTECTIVE CLOTHING

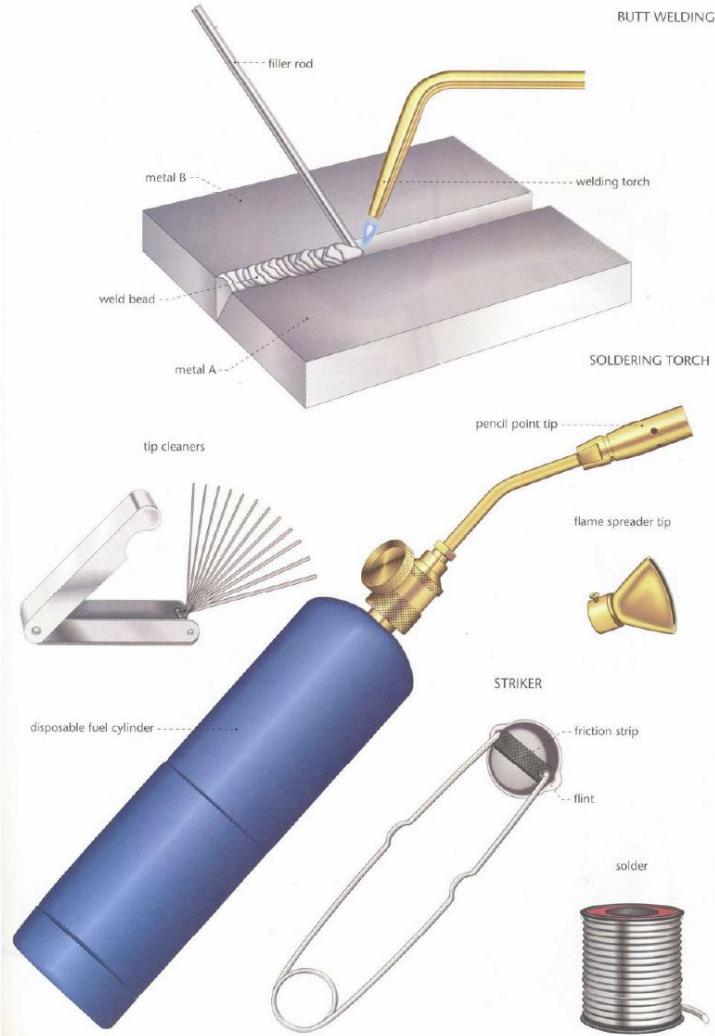



Elettricit 

ELECTRICITY

ELECTRICIAN'S TOOLS

multimeter



voltage tester



drop light



multipurpose tool

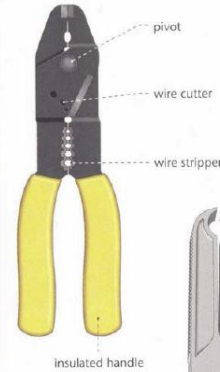

fuse puller



fish wire



hammer



cable ripper

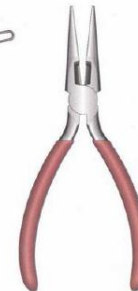

needle-nose pliers

ELECTRICIAN'S TOOLS

lineman's pliers

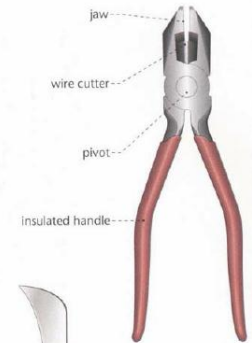

wire nut



cutter

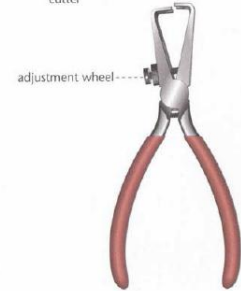

wire stripper





Elettricità - attrezzi

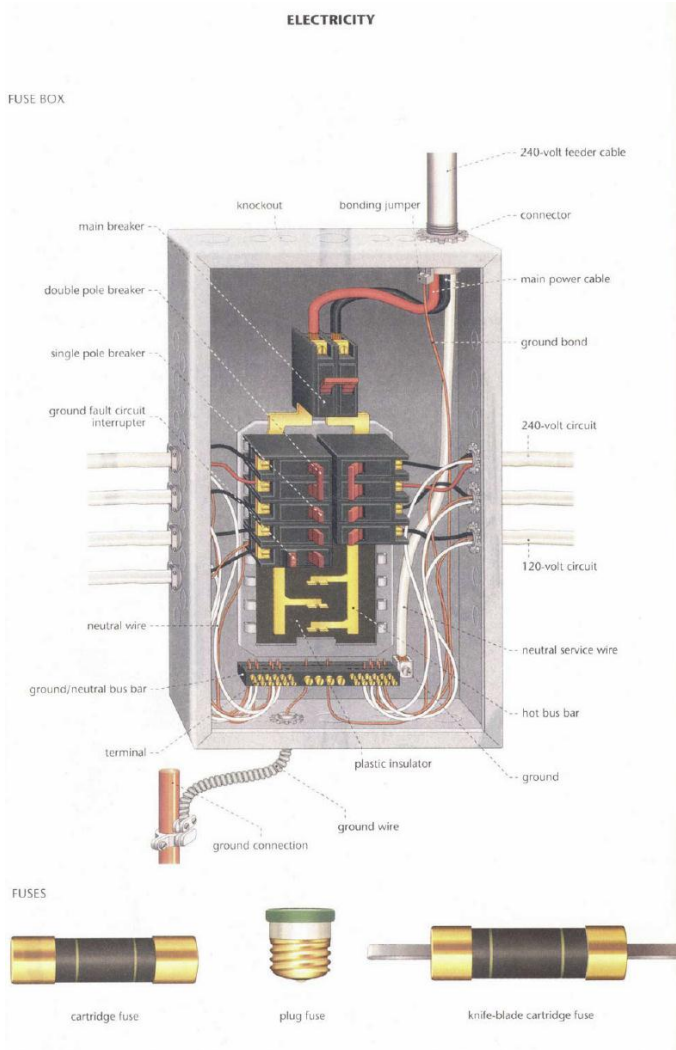

garden tools • les outils de jardin • die Gartengeräte
 • las herramientas de jardinería • gli attrezzi da giardino



Attrezzi

toolbox • la boîte à outils • der Werkzeugkasten • la caja de las herramientas • la scatola degli attrezzi

spanner
la clef
der Schraubenschlüssel
la llave de boca
la chiave

adjustable spanner
• la clef à molette
• der verstellbare Schraubenschlüssel
• la llave inglesa
• la chiave regolabile

hammer • le marteau
• der Hammer • el martillo
• il martello

needle-nose pliers • la pince plate
• die Flachzange • las tenazas de alambre • le pinze ad ago

socket wrench • la clef à pipe • der Steckschlüssel
• la llave de tubo • la chiave a tubo

spirit level
le niveau
die Wasserwaage
el nivel
la livella

washer
le joint
der Dichtungsring
la arandela
la rondella

nut
l'écrou
die Mutter
la tuerca
il dado

bull-nose pliers • la pince universelle
• die Kombinationszange • los alicates
• le pinze tonde

socket • la douille • die Tülle
• el encaje • la bussola

key • la clef • der Schlüssel
• la llave • la chiave

tape measure • le mètre • das Metermaß
• la cinta métrica
• il metro

knife
le couteau
der Schneider
el cutter
il coltello

screwdriver bits
• les embouts de tournevis
• die Schraubenziehereinsätze
• los cabezales de destornillador
• la punte per cacciavite

screwdriver
le tournevis
der Schraubenzieher
el destornillador
il cacciavite

drill bits • les forets • die Bohrer • las brocas • le punte

metal bit • le foret à métaux
• der Metallbohrer • la broca para metal
• la punta per metalli

flat wood bit • le foret à bois plat
• der Flachholzbohrer • la broca para madera
• la punta plana per legno

reamer
l'alésoir
die Reibahle
el escariador
l'alesatore

carpentry bits
• les forets de bois
• die Holzbohrer
• las brocas para madera
• la punta de falegnameria

phillips screwdriver • le tournevis cruciforme
• der Kreuzschlitzschraubenzieher • el destornillador de estrella • il cacciavite a croce

head • la tête
• der Nagelkopf • la cabeza • la testa

security bit
le foret de sécurité
der Sicherheitsbohrer
la broca de seguridad
la punta di sicurezza

masonry bit
le foret de maçonnerie
der Mauerwerkbohrer
la broca de albañilería
la punta per muratura

nail • le clou • der Nagel
• el clavo
• il chiodo

screw • la vis • die Schraub
• el tornillo
• la vite

wire strippers • la pince à dénuder • die Entisolierzange
• el pelacables • la pinza spelafilo

wire cutters • la pince coupante
• der Drahtschneider • el cortaalambrés
• la pinza tagliafilo

soldering iron
le fer à souder
der LötKolben
el soldador
il soldatoio

solder
la soudure
der Lötzinn
el hilo de estaño
le lega per saldatura

insulating tape
le ruban isolant
das Isolierband
la cinta aislante
il nastro isolante

scalpel
le scalpel
das Skalpell
el escalpelo
il bisturi

fretsaw • la scie à chantourner • die Schweißsäge
• la sierra de calar • la sega da traforo

tenon saw • la scie à dossierer • die Profilsäge
• el serrucho de costilla • la sega per tenoni

safety goggles • les lunettes de sécurité
• die Schutzbrille • las gafas de seguridad
• gli occhiali protettivi

plane • le rabot • der Hobel
• el cepillo
• la piella

mitre block • la boîte à onglets
• die Gehrungslade • la caja para cortar en inglete • la cassetta guidalama per ungnature

wire wool • la paille de fer • die Stahlwolle
• la lana de acero
• la lana d'acciaio

hand drill • la perceuse manuelle
• der Handbohrer
• el taladro manual
• il trapano manuale

chisel • le burin • der Meißel
• el formón
• lo scalpello

sharpening stone • la pierre à aiguiser • der Wetzstuhl
• la piedra afiladora • l'affilatore

sandpaper • le papier de verre • das Schmirgelpapier
• el papel de lija
• la carta vetrata

wrench • la clef serre-tube
• die Rohrzange
• las tenazas
• la chiave inglese

plunger • la ventouse • der Sauger
• el desatascador
• lo sturalavandini

pipe cutter • le coupe-tube • der Rohrschneider
• el cortatuberías • il tagliatubi

Parentele - emozioni

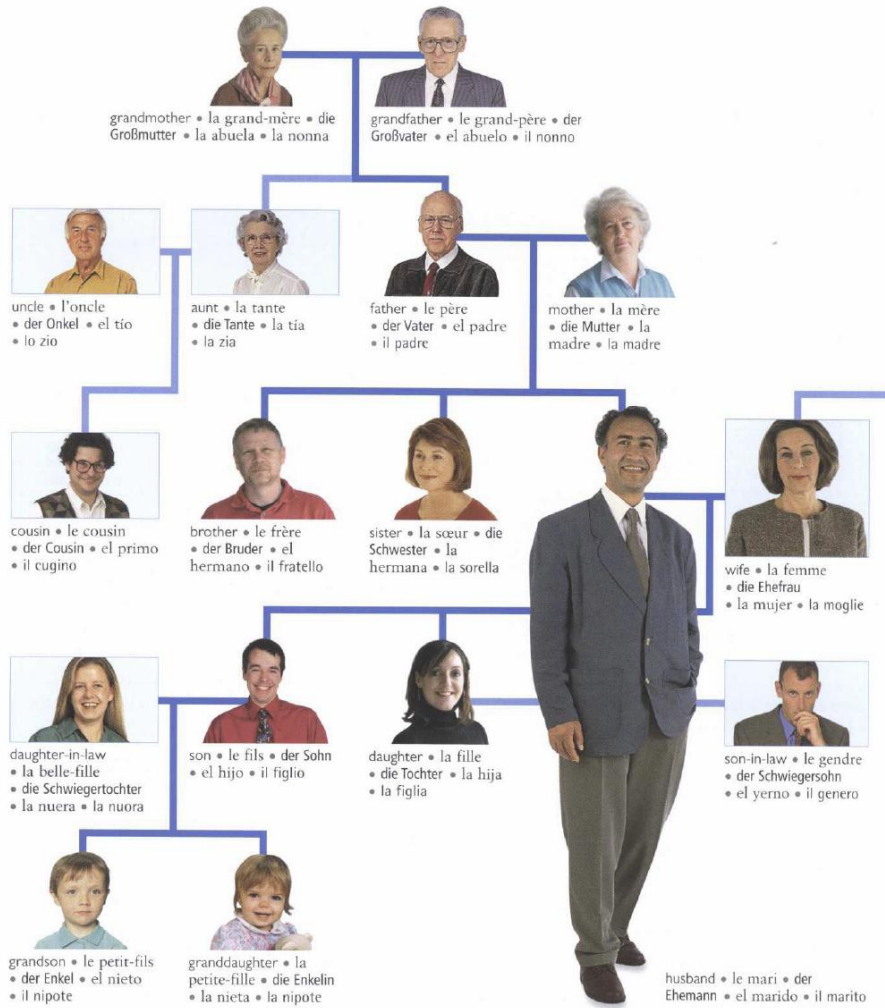

emotions • les émotions • die Gefühle • las emociones • le emozioni



happy • heureux • glücklich • contento • felice

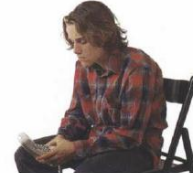

sad • triste • traurig • triste • triste



excited • excité • aufgeregt • entusiasmado • eccitato



bored • ennuyé • gelangweilt • aburrito • annoiato



surprised • surpris • überrascht • sorprendido • sorpreso



scared • effrayé • erschrocken • asustado • spaventato



angry • fâché • verärgert • enfadado • arrabbiato



confused • confus • verwirrt • confuso • confuso



worried • inquiet • besorgt • preocupado • preoccupato



nervous • nerveux • nervös • nervioso • nervoso



proud • fier • stolz • orgulloso • fiero



confident • confiant • selbstsicher • seguro de sí mismo • fiducioso



embarrassed • gêné • verlegen • avergonzado • imbarazzato



shy • timide • schüchtern • timido • timido

upset	laugh (v)	sigh (v)	shout (v)
consterné	rire	soupirer	crier
bestürzt	lachen	seufzen	schreien
triste	reir	suspirar	gitar
turbato	ridere	sospirare	gridare
shocked	cry (v)	faint (v)	yawn (v)
choqué	pleurer	s'évanouir	bâiller
schockiert	weinen	in Ohnmacht fallen	gähnen
horrorizado	llorar	desmayarse	bostezar
scandalizzato	piangere	svenire	sbadigliare



Abiti

blazer • le blazer • der Blazer
• la chaqueta • il blazer

sports jacket • la veste de sport • das Sportjackett • la americana sport • la giacca sportiva

waistcoat • le gilet • die Weste • el chaleco • il gilet

v-neck
l'encolure en V
der V-Ausschnitt
el cuello de pico
il collo a V

round neck
le col rond
der runde Ausschnitt
el cuello redondo
il girocollo

t-shirt
le t-shirt
das T-Shirt
la camiseta
la maglietta

anorak • l'anorak • der Anorak • el chaquetón
• il giaccone

sweatshirt • le sweat-shirt • das Sweatshirt • la sudadera • la felpa

windcheater • le coupe-vent • die Windjacke • la cazadora • la giacca a vento

sweatpants
• le pantalon de jogging
• die Trainingshose
• los pantalones de chándal
• i pantaloni di felpa

sweater • le pullover • der Pullover • el jersey
• il maglione

pyjamas • le pyjama • der Schlafanzug • el pijama
• il pigiama

vest • le tricot de corps • das Unterhemd • la camiseta de tirantes • la canottiera

casual wear • les vêtements sport • die Freizeitkleidung
• la ropa sport • il casual

shorts • le short • die Shorts
• los pantalones cortos
• i calzoncini

briefs • le slip • der Slip
• los calzoncillos • lo slip

boxer shorts • le caleçon • die Boxershorts • los calzoncillos de pata • i boxer

socks • les chaussettes • die Socken • los calcetines
• i calzini

bags • les sacs • die Taschen • los bolsos • le borse

wallet • le portefeuille
• die Brieftasche • la cartera • il portafoglio

purse • le portemonnaie • das Portemonnaie
• el monedero • il portamonete

shoulder bag • le sac à bandoulière • die Umhängetasche • el bolso
• la borsa a tracolla

handbag • le sac à main • die Handtasche • el bolso de mano • la borsetta

backpack • le sac à dos • der Rucksack • la mochila
• lo zainetto

fastening
le fermoir
der Verschluss
el cierre
la cinghia

handles
les poignées
die Griffe
las asas
i manici

shoulder strap
la bretelle
der Schulterriemen
la correa
la bretella

shoes • les chaussures • die Schuhe • los zapatos • le scarpe

walking boot
• le pataugas
• der Wanderschuh
• la bota de trekking
• la scarpa da trekking

trainer • la basket
• der Sportschuh • la zapatilla deportiva
• la scarpa da ginnastica

leather shoe • la chaussure de cuir
• der Lederschuh
• el zapato de piel
• la scarpa di cuoio

flip-flop • la tong
• die Strandsandale • la chancla
• la ciabatta

eyelet
l'œillet
die Öse
el ojal
l'occhiello

lace
le lacet
der Schnürsenkel
la cordonera
il laccio

tongue • la languette
• die Zunge • la lengüeta
• la lingua

heel
le talon
der Absatz
el tacón
il tacco

sole
la semelle
die Sohle
la suela
la suola

lace-up • la chaussure lacée • der Schnürschuh • el zapato de cordoneras
• la scarpa con i lacci

high heel shoe • la chaussure à talon • der Schuh mit hohem Absatz
• el zapato de tacón • la scarpa con il tacco alto

platform shoe • la chaussure à semelle compensée • der Plateauschuh • el zapato de plataforma • lo zatterone

sandal • la sandale
die Sandale • la sandalia • il sandalo

slip-on • le mocassin
der Slipper • el mocasin • il mocassino

brogue • le richelieu
der Herrenhalbschuh • el zapato de caballero
• la scarpa da uomo





Soccorsi

fire brigade • les pompiers • die Feuerwehr • los bomberos • i vigili del fuoco

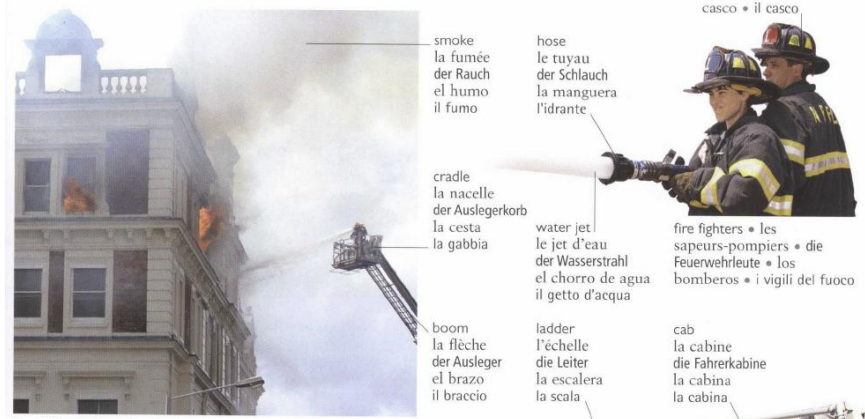

fire • l'incendie • der Brand • el incendio • l'incendio



fire station • le poste d'incendie • die Feuerwache • el parque de bomberos • la caserma dei vigili del fuoco



fire escape • l'escalier de secours • die Feuertreppe • la salida de incendios • la scala di sicurezza



fire engine • la voiture de pompiers • das Löschfahrzeug • el coche de bomberos • l'autopompa



smoke alarm • le détecteur de fumée • der Rauchmelder • el detector de humos • l'allarme antifumo



fire alarm • l'avertisseur d'incendie • der Feuermelder • la alarma contra incendios • l'allarme antincendio



axe • la hache • das Beil • el hacha • l'ascia



fire extinguisher • l'extincteur • der Feuerlöscher • el extintor • l'estintore



hydrant • la borne d'incendie • der Hydrant • la boca de agua • l'idrante

I need the police/fire brigade/ambulance.
La police/les pompiers/une ambulance, s'il vous plaît.
Die Polizei/die Feuerwehr/reinen Krankenwagen, bitte.
Necesito la policia/los bomberos/una ambulancia.
Ho bisogno della polizia/dei vigili del fuoco/di un'ambulanza.

There's a fire at...
Il y a un incendie à...
Die Polizei/die Feuerwehr/reinen Krankenwagen, bitte.
Es brennt in...
Hay un incendio en...
C'è un incendio a...

There's been an accident.
Il y a eu un accident.
Es ist ein Unfall passiert.
Ha habido un accidente.
C'è stato un incidente.

Call the police!
Appelez la police!
Rufen Sie die Polizei!
Llame a la policia!
Chiamate la polizia!

emergency services • les services d'urgence • die Notdienste • los servicios de emergencia • i servizi di emergenza

ambulance • l'ambulance • der Krankenwagen • la ambulancia • l'ambulanza



ambulance • l'ambulance • der Krankenwagen • la ambulancia • l'ambulanza



paramedic • l'infirmier du SAMU • der Rettungssanitäter • el ambulancero • il paramedico

police • la police • die Polizei • la policia • la polizia

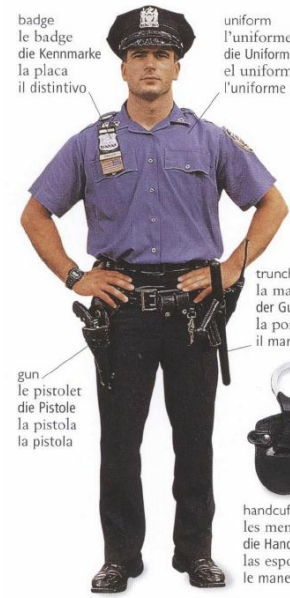

police officer • le policier • der Polizist • el agente de policia • l'agente



police car • la voiture de police • das Polizeiauto • el coche de policia • l'auto della polizia



police station • le poste de police • die Polizeiwache • la estación de policia • la stazione di polizia

inspector l'inspecteur der Inspektor el comisario il commissario	burglary le cambriolage der Einbruchdiebstahl el robo il furto	complaint la plainte die Beschwerde la denuncia la denuncia	arrest l'arrestation die Festnahme el arresto l'arresto
detective l'officier de police der Kriminalbeamte el detective l'investigatore	assault l'agression die Körperverletzung la agresión l'aggressione	investigation l'enquête die Ermittlung la investigación l'indagine	police cell la cellule die Polizeizelle la celda la cella
crime le crime das Verbrechen el crimen el reato	fingerprint les empreintes der Fingerabdruck la huella dactilar l'impronta digitale	suspect le suspect der Verdächtige el sospechoso il sospetto	charge l'accusation die Anklage el cargo l'accusa





Parti anatomiche

face • le visage • das Gesicht • la cara • la faccia

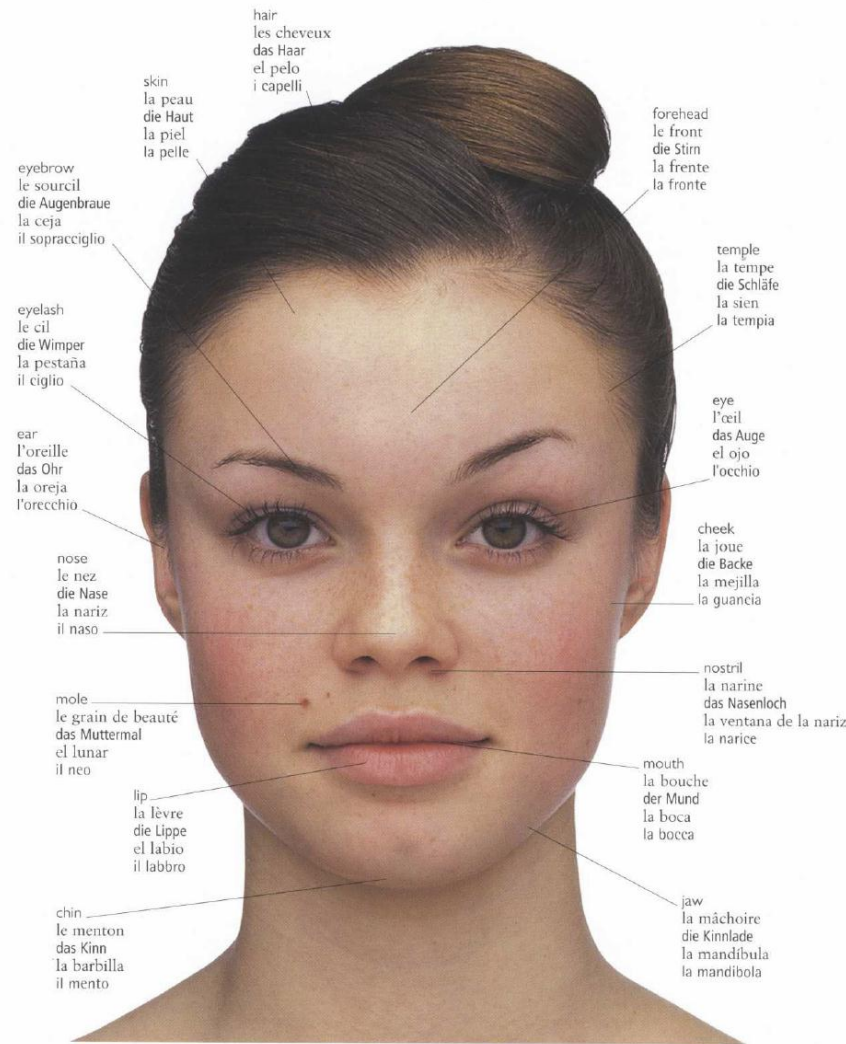

wrinkle • la ride • die Falte
• la arruga • la ruga



freckle • la tache de rousseur
• die Sommersprosse
la peca • la lentiggine



pore • le pore • die Pore
• el poro • il poro



dimple • la fossette
• das Grübchen • el hoyuelo
• la fossetta

hand • la main • die Hand • la mano • la mano

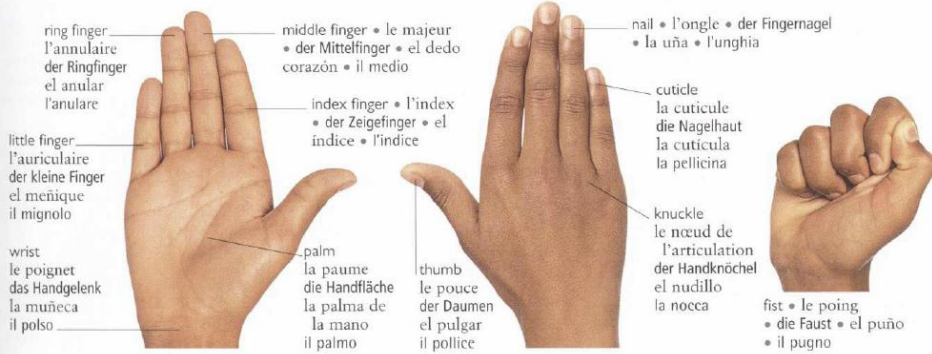

foot • le pied • der Fuß • el pie • il piede





Malattie - Ferite

illness • la maladie • die Krankheit • la enfermedad • la malattia

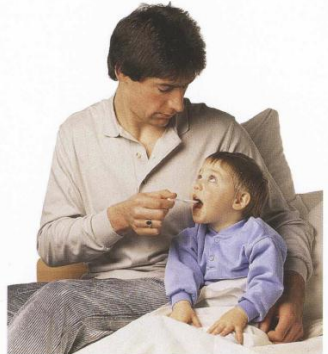

fever • la fièvre • das Fieber • la fiebre
• il febbre



asthma • l'asthme
• das Asthma • el asma
• la asma



headache • le mal de tête • die Kopfschmerzen
• el dolor de cabeza
• il mal di testa



sneeze • l'éternuement
• das Niesen • el estomudo • lo starnuto



nausea • la nausée
• die Übelkeit • la náusea • la nausea



nosebleed • le saignement de nez
• das Nasenbluten
• la hemorragia nasal
• l'emorragia nasale



cold • le rhume • die Erkältung • el resfriado
• il raffreddore



chickenpox • la varicelle • die Windpocken • la varicela • la varicella



cough • la toux
• der Husten • la tos
• la tosse



flu • la grippe • die Grippe • la gripe
• l'influenza



rash • l'éruption
• der Hautausschlag
• el sarpullido
• lo sfgo

injury • la blessure • die Verletzung • la lesión • la ferita



sprain • l'entorse • die Verstauchung • la torcedura • la slogatura



fracture • la fracture • die Fraktur • la fractura • la frattura



whiplash • le coup du lapin
• das Schleudertrauma • el tirón en el cuello • il colpo di frusta



cut • la coupure • der Schnitt
• el corte • il taglio



graze • l'écorchure • die Abschürfung • el arañazo
• la sbucciatura



bruise • la contusion
• die Prellung • el hematoma
• il livido



splinter • l'écharde
• der Splitter • la astilla
• la scheggia



sunburn • le coup de soleil
• der Sonnenbrand
• la quemadura de sol
• la scottatura



burn • la brûlure • die Brandwunde • la quemadura
• l'ustione



bite • la morsure • der Biss
• el mordisco • il morso



sting • la piqure • der Stich
• la picadura • la puntura

heart attack la crise cardiaque der Herzinfarkt el infarto de miocardio l'infarto	diabetes le diabète die Zuckerkrankheit la diabetes el diabetes il diabete	eczema l'eczéma das Ekzem el eccema l'eczema	chill le refroidissement die Verkühlung el resfriado l'infreddatura	vomit (v) vomir sich übergeben vomitar vomitare	diarrhoea la diarrhée der Durchfall la diarrea
stroke l'attaque der Schlaganfall el derrame cerebral l'apoplessia	hayfever le rhume des foins die Heuschnupfen la fiebre del heno la febbre da fieno	infection l'infection die Infektion la infección l'infezione	stomach ache le mal d'estomac die Magenschmerzen el dolor de estómago il mal di stomaco	epilepsy l'épilepsie die Epilepsie la epilepsia l'epilessia	measles la rougeole die Masern el sarampión il morbillo
blood pressure la tension der Blutdruck la tensión arterial la pressione del sangue	allergy l'allergie die Allergie la alergia l'allergia	virus le virus der Virus el virus il virus	faint (v) s'évanouir in Ohnmacht fallen desmayarse svenire	migraine la migraine die Migräne la jaqueca l'emicrania	mumps les oreillons der Mumps las paperas gli orecchioni

accident l'accident der Unfall el accidente l'incidente	haemorrhage l'hémorragie die Blutung la hemorragia l'emorragia	concussion la commotion cérébrale die Gehirnerschütterung la conmoción la commozione	Will he/she be all right? Est-ce qu'il/elle va se remettre? Wird er/sie es gut überstehen? ¿Se pondrá bien? Si rimetterà?
emergency l'urgence der Notfall la urgencia l'emergenza	blisters l'ampoule die Blase la ampolla la vesicula	head injury le traumatisme crânien die Kopfverletzung la lesión en la cabeza la ferita alla testa	Please call an ambulance. Appelez une ambulance s'il vous plaît. Rufen Sie bitte einen Krankenwagen. Por favor llame a una ambulancia. Chiami un'ambulanza, per favore.
wound la blessure die Wunde la herida la ferita	poisoning l'empoisonnement die Vergiftung el envenenamiento l'avvelenamento	electric shock le choc électrique der elektrische Schlag la descarga eléctrica la scossa elettrica	Where does it hurt? Où avez-vous mal? Wo haben Sie Schmerzen? ¿Dónde le duele? Dove le fa male?



Primo soccorso

first aid • les premiers secours • die erste Hilfe • los primeros auxilios • il pronto soccorso



ointment • la pommade • die Salbe
• la pomada • la pomata

plaster • le pansement • das Pflaster • la tiritra
• el cerotto

safety pin
l'épingle de sûreté
die Sicherheitsnadel
el impermeble
la spilla da balia

bandage
le bandage
die Bandage
la venda
la benda

painkillers
les analgésiques
die Schmerztabletten
los analgésicos
gli antidolorifici

antiseptic wipe
la serviette antiseptique
das Desinfektionstuch
la toallita antiséptica
la salvietta antiseptica

tweezers
la pince fine
die Pinzette
las pinzas
le pinzette

scissors
les ciseaux
die Schere
las tijeras
le forbici

antiseptic
l'antiseptique
das Antiseptikum
el desinfectante

gauze • la gaze
• die Gaze
• la gasa
• la garza



dressing • le pansement
• der Verband • el vendaje
• la bandatura



splint • l'attelle • die Schiene • la tablilla • la stecca



adhesive tape
• le sparadrap
• das Leukoplast
• el esparadrapo
• il nastro adesivo

first aid box • la trousse de premiers secours • der Erste-Hilfe-Kasten • el botiquín
• la cassetta di pronto soccorso



resuscitation • la réanimation
• die Wiederbelebung • la reanimación • la rianimazione

shock le choc der Schock el shock lo shock	pulse le pouls der Puls el pulso le pulsazioni	choke (v) étouffer ersticken ahogarse soffocare	Can you help? Est-ce que vous pouvez m'aider? Können Sie mir helfen? ¿Me puede ayudar? Può aiutarmi?
unconscious sans connaissance bewusstlos inconsciente privo di sensi	breathing la respiration steril die Atmung la respiración la respirazione	sterile stérile steril estéril sterile	Do you know first aid? Pouvez-vous donner les soins d'urgence? Beherrschen Sie die Erste Hilfe? ¿Sabe primeros auxilios? Sa dare pronto soccorso?

hospital • l'hôpital • das Krankenhaus • el hospital • l'ospedale

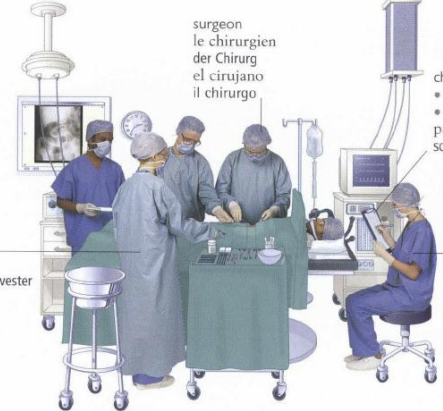

surgeon
le chirurgien
der Chirurg
el cirujano
il chirurgo

nurse
l'infirmière
die Krankenschwester
la enfermera
l'infermiera

anaesthetist
l'anesthésiste
der Anästhesist
el anestésista
l'anestesta

chart • la courbe
• die Patiententabelle
• la gráfica del paciente
• la scheda del paziente

blood test • l'analyse de sang
• die Blutuntersuchung • el análisis de sangre • l'analisi del sangue

injection • l'injection
• die Spritze • la inyección
• l'iniezione

operating theatre • la salle d'opération • der Operationssaal • el quirófano
• la sala operatoria

trolley • le chariot • die fahrbare Liege • la camilla
• la lettiga

call button • le bouton d'appel
• der Rufknopf • el timbre • il pulsante di chiamata



emergency room • la salle des urgences • die Notaufnahme
• la sala de urgencias • la sala emergenze

ward • la salle • die Krankenhausstation • la planta
• il reparto



wheelchair • la chaise roulante • der Rollstuhl
• la silla de ruedas • la sedia a rotelle

x-ray • la radio • die Röntgenaufnahme • la radiografia • la radiografia



scan • la scanographie
• der CT-Scan • la ecografia
• l'ecografia

operation l'opération die Operation die Besuchszeiten la operación l'operazione	discharged renvoyé entlassen dado de alta dimesso	visiting hours les heures de visite die Besuchszeiten las horas de visita l'orario delle visite	maternity ward la maternité die Entbindungsstation la sala de maternidad il reparto maternità	intensive care unit le service de soins intensifs die Intensivstation la unidad de cuidados intensivos il reparto di cura intensiva
admitted admis aufgenommen ingresado ricoverato	clinic la clinique die Klinik la clinica la clinica	children's ward la pédiatrie die Kinderstation la sala de pediatria il reparto pediatrico	private room la chambre privée das Privatzimmer la habitación privada la camera privata	outpatient le malade en consultation externe der ambulante Patient el paciente externo il paziente esterno

Terremoto

camping • le camping • das Camping • el camping • il campeggio



toilets
les toilettes
die Toiletten
los aseos
i bagni

waste disposal
les poubelles
die Mülleimer
el contenedor de la basura
i rifiuti

shower block
les douches
die Duschen
las duchas
le doce

electric hook-up
le branchement électrique
der Stromanschluss
el punto eléctrico
la presa di corrente

flysheets
le double toit
das Überdach
el doble techo
il telo protettivo

tent peg
le piquet
der Hering
la clavija
il piolo

guy rope
la corde
die Zeltspanneleine
la cuerda
la corda

caravan
la caravane
der Wohnwagen
la roulotte

campsite • le terrain de camping • der Campingplatz • el camping • il campeggio

camp (v) camper zelten acampar campeggiare	pitch l'emplacement der Zeltplatz la plaza il posteggio	picnic bench le banc à pique-nique die Picknickbank la mesa de picnic il tavola da picnic	charcoal le charbon de bois die Holzkohle el carbón vegetal la carbonella
site manager's office le bureau du chef die Campingplatzverwaltung la oficina del director l'ufficio del direttore	pitch a tent (v) monter une tente ein Zelt aufschlagen montar una tienda piantare una tenda	hammock le hamac die Hängematte la hamaca l'amaca	firelighter l'allume-feu der Feueranzünder la pastilla para hoguera l'esca per il fuoco
pitches available les emplacements de libre Zeltplätze frei hay plazas libres le piazzole disponibili	tent pole le mât die Zeltstange el palo de la tienda il palo	camper van l'autocaravan das Wohnmobil la camper il camper	light a fire (v) allumer un feu ein Feuer machen encender una hoguera accendere un fuoco
full complet voll completo completo	camp bed le lit de camp das Faltpbett el catre de campana il lettino da campeggio	trailer la remorque der Anhänger el remolque il rimorchio	campfire le feu de camp das Lagerfeuer la hoguera il fuoco



frame
le cadre
das Gestänge
la estructura
la struttura

ground sheet
le tapis de sol
der Zeltboden
el suelo aislante
il telo isolante

backpack
le sac à dos
der Rucksack
la mochila
lo zaino

vacuum flask
le thermos
die Thermosflasche
el termo
il thermos

water bottle
la bouteille d'eau
die Wasserflasche
la cantimplora
la borraccia

tent • la tente • das Zelt • la tienda de campaña • la tenda

insect repellent • le spray contre les insectes • der Insektenspray • la loción contra los insectos • il repellente per insetti

torch • la lampe torche • die Taschenlampe • la linterna • la torcia

thermals
les sous-vêtements thermiques
die Thermowäsche
la ropa termoaíslante
gli indumenti termici

mosquito net
la moustiquaire
das Moskitonetz
la mosquitera
la zanzariera

walking boots • les chaussures de marche • die Wanderschuhe • las botas de trekking • le scarpe da escursionismo

waterproofs • l'imperméable • die Regenhaut • la ropa impermeable • gli indumenti impermeabili

sleeping bag • le sac de couchage • der Schlafsack • el sacco da dormir • il sacco a pelo

camping stove • le réchaud • der Gasbrenner • el hornillo • il fornello da campeggio

barbecue • le barbecue • der Grill • la barbacoa • la griglia per barbecue

sleeping mat
le tapis de sol
die Schlafmatte
la esterilla
il materasso

air mattress • le matelat pneumatique • die Luftmatratze • la colchoneta • il materasso ad aria

Sanitari

bathroom • la salle de bain • das Badezimmer • el cuarto de baño • la stanza da bagno

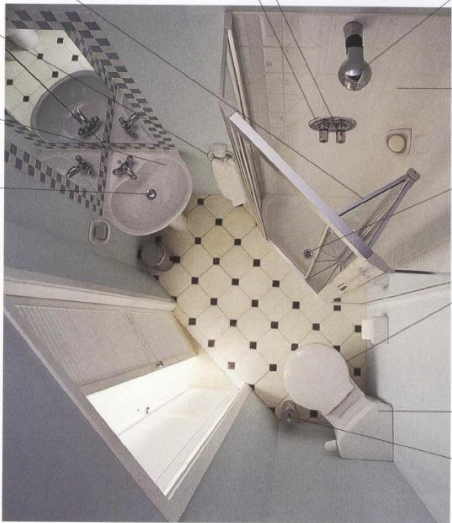

towel rail
le porte-serviettes
der Handtuchhalter
el toallero
il portasciugamani

shower door
la porte de douche
die Duschtür
la puerta de la ducha
la porta della doccia

cold tap
le robinet d'eau froide
der Kaltwasserhahn
el grifo de agua fría
il rubinetto dell'acqua fredda

hot tap
le robinet d'eau chaude
der Heißwasserhahn
el grifo de agua caliente
il rubinetto dell'acqua calda

shower head
le pommeau de douche
der Duschkopf
la alcachofa de la ducha
il soffione della doccia

shower
la douche
die Dusche
la ducha
la doccia

drain
le ruyau d'écoulement
der Abfluss
el desagüe
lo scolo

toilet seat
le siège des toilettes
der Toiletensitz
la tapa del wáter
il sedile

toilet
les toilettes
die Toilette
el wáter
il water

toilet brush
la brosse
die Toilettenbürste
la escobilla del wáter
la spazzola da water

washbasin
le lavabo
das Waschbecken
el lavabo
il lavandino

plug
la bonde
der Stöpsel
el tapón
il tappo

bathub • la baignoire
• die Badewanne • la bañera
• la vasca

bidet • le bidet • das Bidet
• el bidé • il bidé

medicine cabinet
la pharmacie de ménage
die Hausapotheke
el armario de las medicinas
l'armadietto dei medicinali

toilet roll
le rouleau de papier hygiénique
die Rolle Toilettenpapier
el rollo de papel higiénico
la carta igienica

take a shower (v)
prendre une douche
duschen
darse una ducha
farsi la doccia

bath mat
le tapis de bain
die Badematte
la alfombrilla de baño
lo scendibagno

shower curtain
le rideau de douche
der Duschvorhang
la cortina de ducha
la tenda da doccia

take a bath (v)
prendre un bain
baden
darse un baño
farsi il bagno

dental hygiene • l'hygiène dentaire • die Zahnpflege
• la higiene dental • l'igiene dentale

toothbrush • la brosse à dents • die Zahnbürste
• el cepillo de dientes
• lo spazzolino da denti

toothpaste • le dentifrice
• die Zahnpasta • la pasta de dientes
• el dentífrico

dental floss
le fil dentaire
die Zahnseide
el hilo dental
il filo interdentale

mouthwash • l'eau dentifrice
• das Mundwasser • el enjuague bucal • el collutorio

loofah
le luffa
der Luffaschwamm
la esponja de luffa
la luffa

sponge • l'éponge • der Schwamm • la esponja
• la spugna

pumice stone • la pierre ponce • der Bimsstein • la piedra pómez • la pomice

back brush • la brosse pour le dos • die Rückenbürste
• el cepillo para la espalda
• la spazzola

deodorant • le déodorant
• das Deo • el desodorante
• il deodorante

soap dish
le porte-savon
die Seifenschale
la jabanera
il portasapone

shower gel
le gel douche
das Duschgel
el gel de ducha
la doccia schiuma

soap • le savon • die Seife
• el jabón • il sapone

face cream • la crème pour le visage • die Gesichtcreme
• la crema para la cara
• la crema per il viso

bubble bath • le bain moussant • das Schaumbad
• el gel de baño
• il bagnoschiuma

hand towel
la serviette
das Handtuch
la toalla de lavabo
l'asciugamano piccolo

bath towel
la serviette de bain
das Badetuch
la toalla de baño
l'asciugamano grande

soaps • les serviettes • die Handtücher • las toallas • gli asciugamani

body lotion • la lotion pour le corps • die Körperlotion • la leche del cuerpo • la lozione per il corpo

talcum powder • le talc • der Körperpuder • los polvos de talco • il talco

bathrobe • le peignoir
• der Bademantel • el albornoz
• l'accappatoio

shaving • le rasage • das Rasieren • el afeitado • la rasatura

electric razor
le rasoir électrique
der Elektrorasierer
la maquinilla eléctrica
il rasoio elettrico

shaving foam • la mousse à raser • der Rasierschaum
• la espuma de afeitar
• la schiuma da barba

razor blade
la lame de rasoir
die Rasierklinge
la hoja de afeitar
la lametta

disposable razor • le rasoir jetable • der Einwegrasierer
• la cuchilla de afeitar
desechable • il rasoio monouso









aftershave • l'after-shave
• das Rasierwasser • el aftershave • il dopobarba

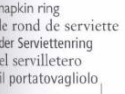
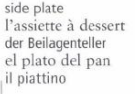

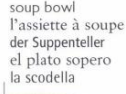
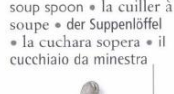
Stoviglie

crockery and cutlery • la vaisselle et les couverts • das Geschirr und das Besteck
 • la vajilla y los cubiertos • le stoviglie e le posate

 mug • la grande tasse • der Becher • la taza • la tazza	 coffee cup • la tasse à café • die Kaffeetasse • la taza de café • la tazzina da caffè	 teacup • la tasse à thé • die Teetasse • la taza de té • la tazza da tè	 plate • l'assiette • der Teller • el plato • il piatto	 bowl • le bol • die Schüssel • el bol • la ciotola
 teapot • la théière • die Teekanne • la cafetera de émbolo • la caffettiera	 jug • le pot • das Kännchen • la jarra • la brocca	 egg cup • le coquetier • der Eierbecher • la huevera • il portauovo	 tumbler le verre das Wasserglas el vaso il bicchiere	 wine glass • le verre à vin • das Weinglas • la copa de vino • il calice da vino
 cafetière • la cafetière • die Cafetière • la cafetera de émbolo • la caffettiera	 teapot • la théière • die Teekanne • la cafetera de émbolo • la caffettiera	 jug • le pot • das Kännchen • la jarra • la brocca	 tumbler le verre das Wasserglas el vaso il bicchiere	 glassware • la verrerie • die Glaswaren • la cristalleria • la cristalleria

 napkin ring le rond de serviette der Serviettenring el servilletero il portatovagliolo	 side plate l'assiette à dessert der Beilagenteller el plato del pan il piattino	 dinner plate l'assiette plate der Essteller el plato llano il piatto piano	 soup bowl l'assiette à soupe der Suppenteller el plato soperro la scodella	 soup spoon • la cuiller à soupe • der Suppenlöffel • la cuchara soperra • il cucchiaino da minestra
 napkin la serviette die Serviette la servilleta il tovagliolo	 fork • la fourchette • die Gabel • el tenedor • la forchetta	 place setting • le couvert • das Gedeck • el cubierto • il coperto	 spoon la cuiller der Löffel la cuchara il cucchiaino	 knife le couteau das Messer el cuchillo il coltello

 frying pan • la poêle • die Bratpfanne • la sartén • la padella	 saucepan • la casserole • der Kochtopf • el cazo • la pentola	 grill pan • le grill • das Grillblech • la parrilla • la padella per grigliare	 wok • le wok • der Wok • el wok • il wok	 earthenware dish • le fait tout • der Schmortopf • la cazuela de barro • la casseruola di terracotta
 mixing bowl • le grand bol • die Rührschüssel • el cuenco • la scodella	 soufflé dish • le moule à soufflé • die Soufflémform • el molde para suflé • lo stampo per soufflé	 gratin dish • le plat à gratin • die Auflaufform • la fuente para gratinar • il piatto da gratin	 ramekin • le ramequin • das Auflaufförmchen • el molde individual • lo stampo	 casserole dish • la cocotte • die Kasserolle • la cazuela • la casseruola

 scales • la balance • die Haushaltswaage • la báscula de cocina • la bilancia	 measuring jug • le pot gradué • der Messbecher • la jarra graduada • il bricco misuratore	 cake tin • le moule à gâteaux • die Kuchenform • el molde para bizcocho • lo stampo per dolci	 pie tin • la tourtière • die Pastetenform • el molde redondo • lo stampo per torte	 flan tin • le moule à tarte • die Obstkuochenform • la flanera • lo stampo per flan
 pastry brush • le pinceau à pâtisserie • der Backpinsel • la brocha de cocina • il pennello da cucina	 rolling pin • le rouleau pâtissier • das Nudelholz • el rodillo de cocina • il mattarello	 muffin tray • le moule à muffins • die Törtchenform • el molde para magdalenas • la teglia per pasticcini	 cooling rack • la grille de refroidissement • das Abkühlgitter • la rejilla • la gratella	 oven glove • le gant isolant • der Topfhandschuh • la manopla de cocina • el guanto da forno





Pulizie

cleaning equipment • l'équipement d'entretien • die Reinigungsartikel • el equipo de limpieza
• gli accessori per la pulizia



suction hose • le tuyau flexible • der Saugschlauch • el tubo de la aspiradora • il tubo di aspirazione



brush
la balayette
der Handfeger
el cepillo
la spazzola



bleach • l'eau de Javel
• das Reinigungsmittel • la lejía
• la varechina



duster • le chiffon
• das Staubtuch
• el trapo del polvo
• lo spolverino



dust pan • la pelle • die Müllschaufel
• el recogedor • la paletta



liquid
le liquide
die Flüssigkeit
liquido



bucket
le seau
der Eimer
el cubo
il secchio



powder
la poudre
das Pulver
en polvo
en polvere



vacuum cleaner • l'aspirateur
• der Staubsauger • la aspiradora • l'aspirapolvere



mop • le balai laveur • der Mopp
• la fregona • la scopa di spugna



detergent • le détergent • das Waschmittel • el detergente
• il detergente



polish • la cire • die Politur
• la cera • la cera

activities • les activités • die Tätigkeiten • las acciones • le attività



clean (v) • nettoyer • putzen
• limpiar • pulire



wash (v) • laver • spülen
• fregar • lavare



wipe (v) • essuyer • wischen
• pasar la bayeta • asciugare



scrub (v) • laver à la brosse
• schrubben • restregar
• fregare



scrape (v) • racler • kratzen
• raspar • raschiare



sweep (v) • balayer • fegen
• barrer • spazzare



dust (v) • épousseter • Staub wischen
• limpiar el polvo
• spolverare



polish (v) • cirer • polieren
• sacar brillo • lucidare

utility room • la buanderie • der Allzweckraum • el lavadero
• la lavandería

laundry • le linge • die Wäsche • la colada • il bucato



dirty washing
le linge sale
die schmutzige Wäsche
la ropa sucia
i panni sporchi



washing machine • le lave-linge • die Waschmaschine • la lavadora • la lavatrice



washer-dryer • le lave-linge séchant • der Waschautomat mit Trockner • la lavadora secadora • il lavasciuga



tumble dryer • le sèche-linge • der Trockner • la scedadora • l'asciugabiancheria



clean clothes
le linge propre
die saubere Wäsche
la ropa limpia
i vestiti puliti



laundry basket • le panier à linge • der Wäschekorb • el cesto de la colada • il cesto della biancheria da lavare



ironing board • la planche à repasser • das Bügelbrett
• la tabla de la plancha • l'asse da stiro



clothes peg
la pince à linge
die Wäscheklammer
la pinza para la ropa
la molletta



iron • le fer à repasser
• das Bügeleisen • la plancha
• il ferro da stiro

dry (v) • sécher • trocknen • secar • asciugare

load (v) charger füllen cargar caricare	spin (v) essorer schleudern centrifugar centrifugare	iron (v) repasser bügeln planchar stirare	How do I operate the washing machine? Comment fonctionne le lave-linge? Wie benutze ich die Waschmaschine? ¿Cómo funciona la lavadora? Come funziona la lavatrice?
rinse (v) rincer spülen aclerar sciacquare	spin dryer l'essoreuse die Wäscheschleuder la centrifugadora la centrifuga	fabric conditioner le produit assouplissant der Weichspüler el suavizante l'ammorbidente	What is the setting for coloureds/whites? Quel est le programme pour les couleurs/le blanc? Welches Programm nehme ich für farbige/weiße Wäsche? ¿Cuál es el programa para la ropa de color/blanca? Qual è il programma per i tessuti colorati/bianchi?



Fast food

drinks • les boissons • die Getränke • las bebidas • le bevande

water • l' eau • das Wasser • el agua • l'acqua

bottled water
l'eau en bouteille
das Flaschenwasser
el agua embotellada
l'acqua in bottiglia

sparkling
gazeux
mit Kohlensäure
con gas
frizzante

tap water • l'eau du robinet
• das Leitungswasser • el agua
de grifo • l'acqua dal rubinetto

still
non gazeux
ohne Kohlensäure
sin gas
liscia

tonic water • le tonic
• das Tonicwater
la tónica • l'acqua
tonica

soda water • le soda
• das Sodawasser • la
soda • la soda

mineral water • l'eau minérale • das Mineralwasser
• el agua mineral • l'acqua minerale

hot drinks • les boissons chaudes • die
heißen Getränke • las bebidas calientes
• le bevande calde

teabag • le sachet de thé
• der Teebeutel • la bolsita
de té • la bustina di tè

loose leaf tea •
les feuilles de thé
• die Teeblätter
• el té en hoja
• il tè sciolto

tea • le thé • der Tee • el té • il tè

beans • les grains •
die Bohnen • los
granos • i chicchi

ground coffee
le café moulu
der gemahlene Kaffee
il caffè macinato

coffee • le café • der Kaffee • el café • il caffè

hot chocolate • le
chocolat chaud • die
heiße Schokolade • el
chocolate caliente
• il cioccolato caldo

malted drink • la
boisson maltée • das
Malzgetränk • la bebida
malteada • la bevanda
al malto

soft drinks • les boissons non alcoolisées • die alkoholfreien Getränke • los refrescos • le bibite

straw • la paille
• der Strohhalm • la
pajita • la cannuccia

tomato juice • le jus de
tomate • der Tomatensaft
• el zumo de tomate
• il succo di pomodoro

grape juice • le jus de
raisin • der Traubensaft
• el zumo de uva
• il succo d'uva

lemonade • la limonade
• die Limonade • la
limonada • la
limonata

orangeade • l'orangeade
• die Orangeade • la
naranja • la spremuta
d'arancia

cola • le coca
• die Cola • la cola
• la coca

<p>hamburger • le hamburger • der Hamburger • la hamburguesa • l'hamburger</p>	<p>bun le petit pan das Brötchen el bollo il panino</p>	<p>veggie burger • le hamburger végétarien • der vegetarische Hamburger • la hamburguesa vegetariana • l'hamburger vegetariano</p>	<p>hot dog • le hot-dog • das Hot Dog • el perrito caliente • l'hot dog</p>
<p>sandwich • le sandwich • der Sandwich • el bocadillo • il tramezzino</p>	<p>club sandwich • le sandwich mixte • der Klubsandwich • el club sandwich • il tramezzino a strati</p>	<p>open sandwich • le canapé • das belegte Brot • el sandwich abierto • il tramezzino aperto</p>	<p>wrap • le taco • das gefüllte Fladenbrot • el taco • la piadina</p>
<p>kebab • le kébab • der Kebab • el pincho moruno • il kebab</p>	<p>chicken nuggets • les beignets de poulet • die Hähnchenstückchen • las porciones de pollo • i bocconcini di pollo</p>	<p>crêpes • les crêpes • die Crêpes • la crêpe • la crepe</p>	<p>sweet sucré süß dulce dolce</p>
<p>fish and chips • le poisson avec des frites • der Bratfisch mit Pommes frites • el pescado y las patatas fritas • il pesce con patatine</p>	<p>ribs • les côtes • die Rippen • las costillas • le costolette</p>	<p>fried chicken • le poulet frit • das gebratene Hähnchen • el pollo frito • il pollo fritto</p>	<p>pizza • la pizza • die Pizza • la pizza • la pizza</p>

Misure

weights and measures • les poids et mesures • die Maße und Gewichte
• los pesos y las medidas • i pesi e le misure

area • la superficie • die Fläche • el área • la superficie

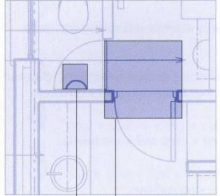

square foot
le pied carré
der Quadratfuß
el pie cuadrado
il piede quadro

square metre
le mètre carré
der Quadratmeter
el metro cuadrado
il metro quadro

distance • la distance
• die Entfernung • la distancia • la distanza

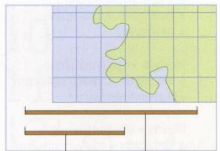

kilometre
le kilomètre
der Kilometer
el kilómetro
il chilometro

mile
le mille
die Meile
la milla
il miglio

length • la longueur • die Länge • la longitüd • la lunghezza



millimetre • le millimètre
• der Millimeter • el milimetro
• il millimetro

centimetre • le centimètre
• der Zentimeter • el centimetro
• il centimetro

inch • le pouce • der Zoll
• la pulgada • il pollice

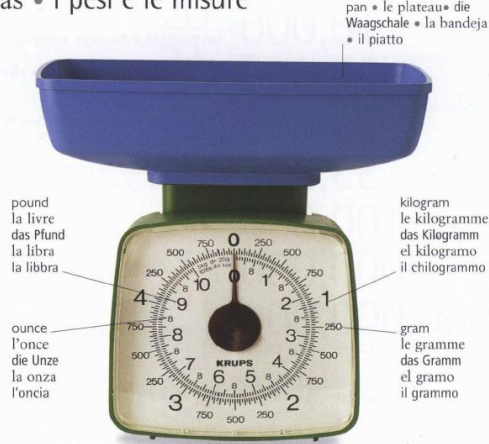

pan • le plateau • die Waagschale • la bandeja
• il piatto

ounce
l'once
die Unze
la onza
l'oncia

pound
la livre
das Pfund
la libra
la libbra

gram
le gramme
das Gramm
el gramo
il grammo

kilogram
le kilogramme
das Kilogramm
el kilogramo
il chilogrammo

scales • la balance • die Waage • la balanza • la bilancia

yard le yard das Yard la yarda la iarda	tonne la tonne die Tonne la tonelada la tonnellata	measure (v) mesurer messen medir misurare
metre le mètre der Meter el metro il metro	milligram le milligramme das Milligramm el miligramo il milligrammo	weigh (v) peser wiegen pesar pesare

capacity • la capacità • das Fassungsvermögen • la capacidad • la capacità

half-litre • le demi-litre • der halbe Liter • el medio litro
litro

litre • le litre
der Liter
el litro
il litro

millilitre
le millilitre
der Milliliter
el mililitro
il millilitro

pinch • la pinte
• das Pint • la pinta
• la pinta

volume • le volume
• das Volumen • el volumen • il volume



measuring jug • le pot gradué • der Messbecher • la jarra
graduada • la brocca graduata

gallon
le gallon
die Gallone
el galón
il gallone

quart
deux pintes
das Quart
el cuarto de galón
il quarto di gallone

litre
le litre
der Liter
el litro
il litro

container • le récipient • der Behälter • el recipiente • il contenitore



carton • le carton • die Tüte
• el tetrabrik • il cartone



packet • le paquet
• das Päckchen • el paquete
• il pacchetto



bottle • la bouteille
• die Flasche • la botella
• il bottiglia



bag • le sac
• der Beutel
• la bolsa
• il sacchetto



tub • le pot • die Dose
• la tarrina • la vaschetta



jar • le pot • das Glas
• el tarro • il barattolo



tin • la boîte • die Dose
• la lata • la scatoletta

can • la boîte
• die Dose • la lata
• la lattina



liquid dispenser • le pulvérisateur
• die Spritze • el pulverizador
• il nebulizzatore



tube • le tube • die Tube
• el tubo • il tubetto



roll • le rouleau • die Rolle
• el rollo • il rotolo



pack • le paquet • das Päckchen • el paquete
• il pacchetto



spray can • la bombe
• die Sprühdose • el spray
• la bomboletta spray



**Associazione Nazionale Carabinieri
Sezione di Brugherio – “Virgo Fidelis”
71° Nucleo Volontariato e Protezione Civile**

Via San Giovanni Bosco, 29
20861 Brugherio (MB)
e-mail: info@anc-brugherio.it
Web: www.anc-brugherio.it

